

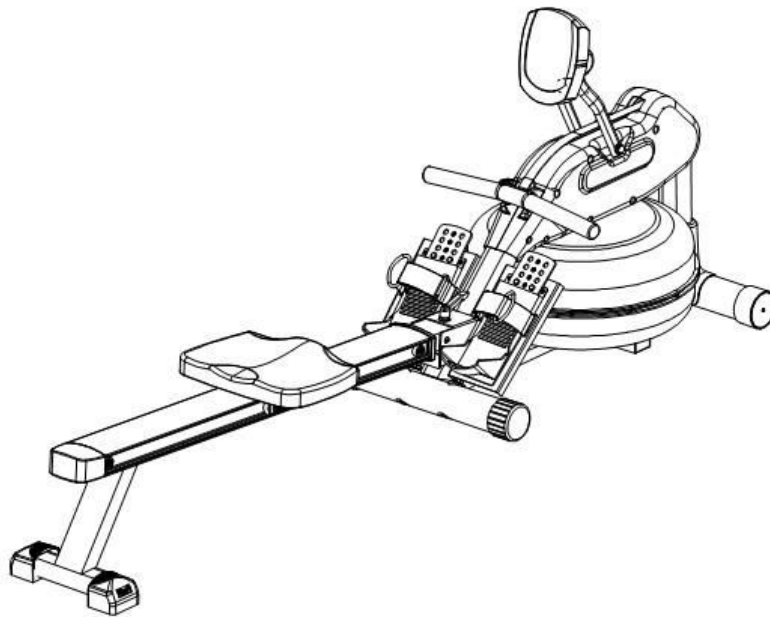

USER MANUAL – EN

IN 16144 Rowing Machine inSPORTline Wateres



CONTENTS

- SAFETY PRECAUTIONS 3
- EXPLODED DRAWING..... 4
- PARTS LIST 5
- ASSEMBLY INSTRUCTIONS 8
 - STEP 1 8
 - STEP 2 8
 - STEP 3 8
 - STEP 4 8
 - STEP 5 8
 - STEP 6 8
- HOW TO FILL AND EMPTY THE TANK 9
- WATER LEVEL..... 9
- FITNESS METER 10
 - BUTTON FUNCTIONS 10
 - FUNCTIONS 11
- PRESET VALUES 11
- PULSE RECOVERY FUNCTION..... 11
- BATTERY INSTALLATION AND REPLACING..... 13
- STORAGE 13
- MAINTENANCE 14
- EXERCISE GUIDE..... 14
 - BASIC ROWING STROKE 14
 - TRAINING TIME..... 15
 - ROWING STYLE ALTERNATION 15
- EXERCISE INSTRUCTIONS..... 15
 - 1. WARM-UP PHASE 16
 - 2. EXERCISE PHASE..... 16
 - 3. COOL-DOWN PHASE..... 17
- MUSCLE TONING..... 17
- WEIGHT LOSS 17
- ENVIRONMENT PROTECTION 17
- TERMS AND CONDITIONS OF WARRANTY, WARRANTY CLAIMS 17

SAFETY PRECAUTIONS

- Read this manual carefully before first using and retain it for future reference.
- Observe all warnings and precautions including assembly steps. Use it only for intended purpose.
- Assemble and use it only according to this manual to assure your safety. Inform all other users about safe usage.
- Keep it away from children and pets. Don't let children unattended near this device. Only an adult person may assemble and use it.
- Ask your physician for advice before starting any exercise program. It is especially necessary if you suffer from some health problems or if you take some medication that could affect your heart rate, blood pressure or cholesterol level.
- Observe body signals. If you feel some problems (pain, tightness in chest, irregular heartbeat, breathing shortness, dizziness or nausea), stop immediately. Improper exercising can result in serious health problems or in an injury.
- Put it only on a flat, dry and clean surface and keep a safety clearance of at least 0.6 m from other objects for higher safety. Use a protective cover to protect carpet or floor.
- Wear adequate sports clothes and sports shoes. Avoid too loose clothes.
- Don't use it outdoors.
- Check this device for damage or wearing before each using. Regularly check all bolts and nuts. They should be well tightened. Re-tighten, if necessary. Never use damaged or worn device to assure your safety.
- If some sharp edges occur, stop using.
- If you hear some unusual noises coming from this device, stop using.
- No adjustable part should protrude and obstruct user movements. Only one person may use it at time.
- Braking is independent of the speed.
- It is not intended for therapeutic purpose.
- Pay attention while lifting or transporting it to avoid back injury. Use only proper lifting techniques or ask some other person for help.
- Don't do any improper modification of this product. If necessary, contact authorized service.
- **Weight limit:** 150 kg
- **Category:** HC (according to EN957 norm) suitable for home using
- **WARNING!** The heart rate frequency monitoring may not be completely accurate. Overexertion during training can lead to a serious injury or even death. If you start to feel faint, stop the exercise immediately.

EXPLODED DRAWING

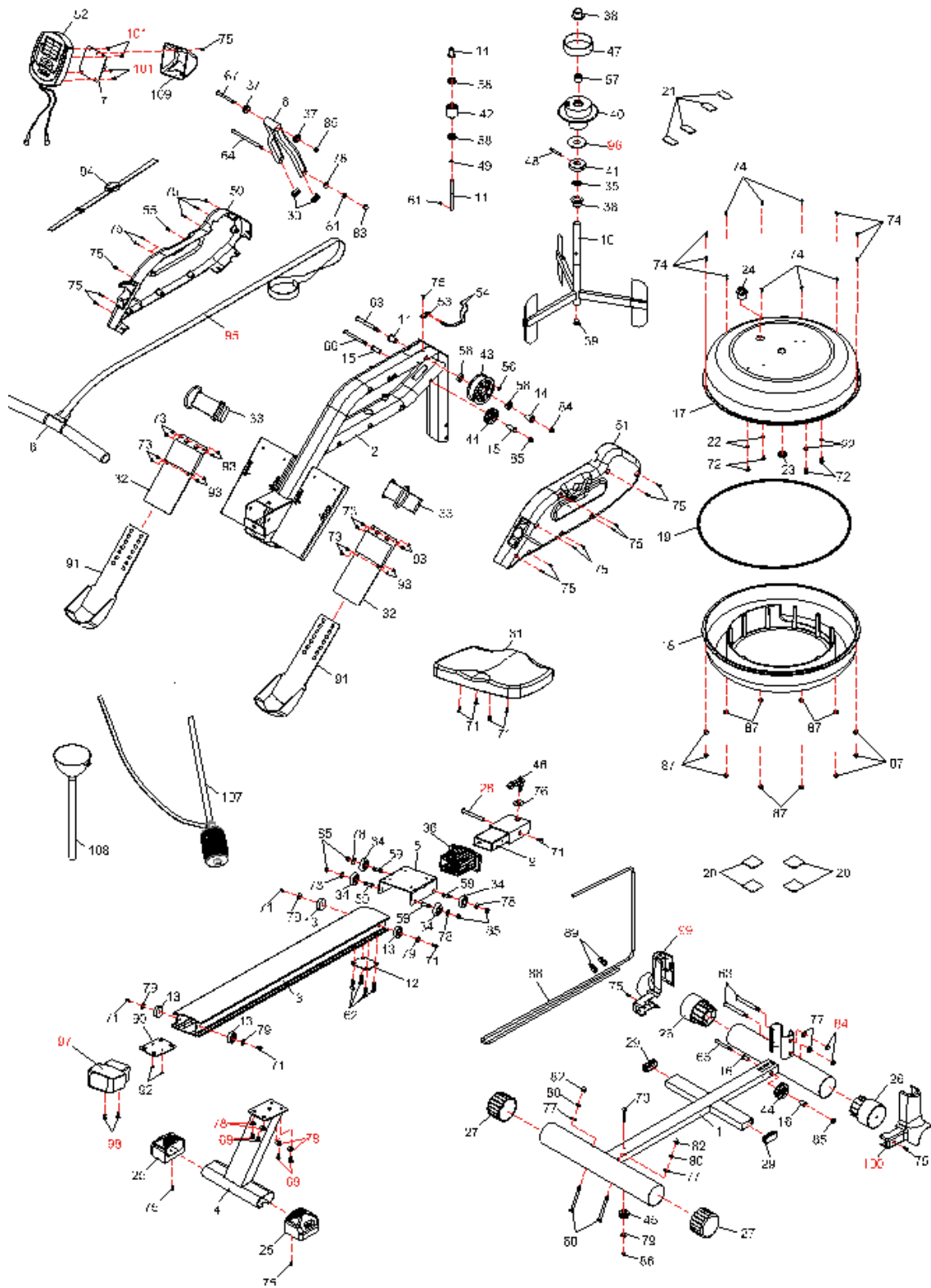

PARTS LIST

No.	Description	Qty.
1	Base frame	1
2	Main frame	1
3	Rail	1
4	Rear stand	1
5	Seat carriage	1
6	Meter post	1
7	Support plate	1
8	Handlebar	1
9	Rail connector	1
10	Impeller	1
11	Impeller shaft	1
12	Rail support	1
13	Stopper	4
14	Strap pulley bushing	3
15	Bungee cord pulley bushing	2
16	Small bungee cord pulley bushing	2
17	Upper tank	1
18	Lower tank	1
19	Rubber ring seal	1
20	Lower pad	4
21	Upper pad	4
22	Plastic washer (ø13)	4
23	Impeller shaft seal	1
24	Fill plug	1
25	Adjustable end cap	2
26	Wheel end cap	2
27	Round end cap	2
28	Barrel nut (M8)	1
29	Rectangular plug	2
30	Oval plug	2
31	Seat	1
32	Pedal support	2
33	Pedal strap	2
34	Roller	4
35	Roller bearing	1
36	Front end cap	1

37	Plastic bushing	2
38	Strap/bungee pulley bushing	2
39	Round plug	1
40	Strap/bungee pulley	1
41	Shaft retainer	1
42	Idle roller	1
43	Strap pulley	1
44	Bungee pulley	2
45	Small bungee pulley	1
46	Fixing lever	1
47	Hook pad	1
48	Spring pin	1
49	E-ring	1
50	Left cover	1
51	Right cover	1
52	Meter	1
53	Sensor holder	1
54	Sensor wire	2
55	Grommet	1
56	Magnet	1
57	One-way bearing	1
58	Bearing	4
59	Bolt (M8*30)	4
60	Carriage bolt (M8*90)	2
61	Set screw (M5*8)	1
62	Bolt (M8*20)	2
63	Bolt (M10*95)	3
64	Bolt (M8*130)	1
65	Bolt (M6*58)	1
66	Bolt (M8*95)	1
67	Bolt M8*85)	1
68	Bolt (M8*65)	1
69	Bolt (M8*15)	4
70	Bolt (M6*50)	1
71	Bolt (M6*15)	7
72	Stainless bolt (M6*15)	4
73	Bolt (M5*12)	8
74	Stainless screw (M3*20)	12

75	Screw (M4*15)	22
76	Washer (ø10)	1
77	Arc washer (ø10)	4
78	Washer (ø8)	9
79	Washer (ø6)	4
80	Lock washer (ø10)	2
81	Lock washer (ø8)	1
82	Acorn nut (M10)	2
83	Acorn nut (M8)	1
84	Nylock nut (M10)	3
85	Nylock nut (M8)	7
86	Nylock nut (M6)	2
87	Stainless nylock nut (M3)	12
88	Bungee cord	1
89	Nylon strap	2
90	Plate	1
91	Pedal cap	2
92	Bolt (M4*10)	2
93	Nylock nut (M5)	8
94	Chest belt (optional)	1
95	Strap	1
96	Plastic washer (ø20)	1
97	Rear end cap	1
98	Bolt (M5*10)	2
99	Left front cover	1
100	Right front cover	1
101	Screw (M5*10)	4
102	Socket wrench	1
103	Allen wrench (5 mm)	1
104	Allen wrench (6 mm)	1
105	Combination wrench	1
106	Caution label	1
107	Syphon pump	1
108	Funnel	1
109	Console cover	1

ASSEMBLY INSTRUCTIONS

STEP 1

- Attach the rear stand (4) to the rail (3) with four bolts M8*15 (69) and washers $\varnothing 8$ (78).

STEP 2

- Slide the seat (31) onto the rail (3). Insert rear end cap (97) into the rail (3) and secure with two screws (98).

STEP 3

- Secure the two stoppers (13) onto the rail (3) with two bolts (71) and washers $\varnothing 6$ (79).

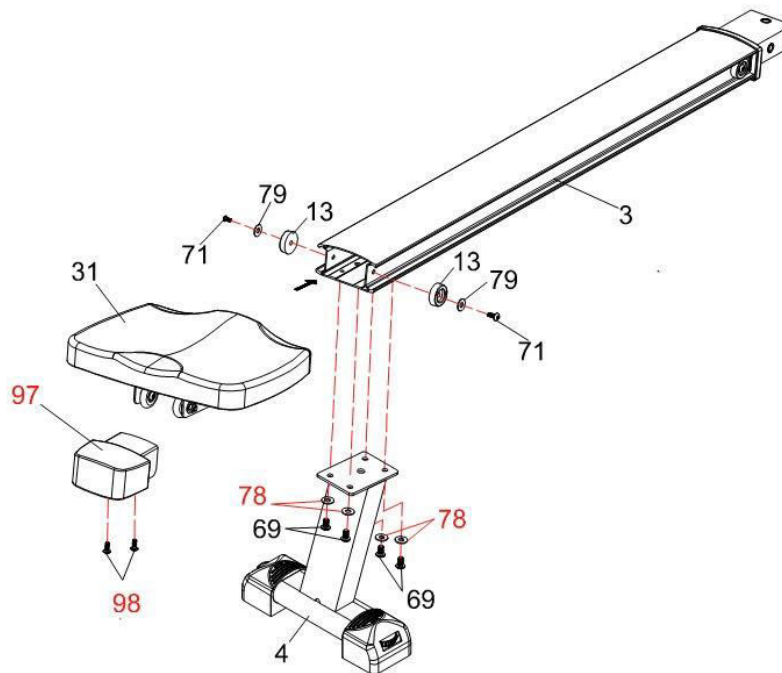

STEP 4

- Attach the rail (3) to the main frame (2) with one bolt M6*15 (71) and one barrel nut M8 (28). Lock the rail (3) in unfolded position using a fixing lever (46) and one washer $\varnothing 10$ (76).
- NOTE: After tightening the fixing lever (46), the rear stabilizer of the base frame (1) might be raised off the floor slightly. It is normal state. It will lean the floor after the user sits on.

STEP 5

- Insert batteries into the meter (52). Attach the meter post (6) to the main frame (2) using one bolt M8*130 (64), one washer $\varnothing 8$ (78), one lock washer $\varnothing 8$ (81) and acorn nut M8 (83).

STEP 6

- Clip the grommet (55) onto both sensor wires (54). Then press the grommet (55) into the left cover (50). Connect the sensor wire (54) to the connection wire of the meter (52). Push the excess wires back into the left cover (50).

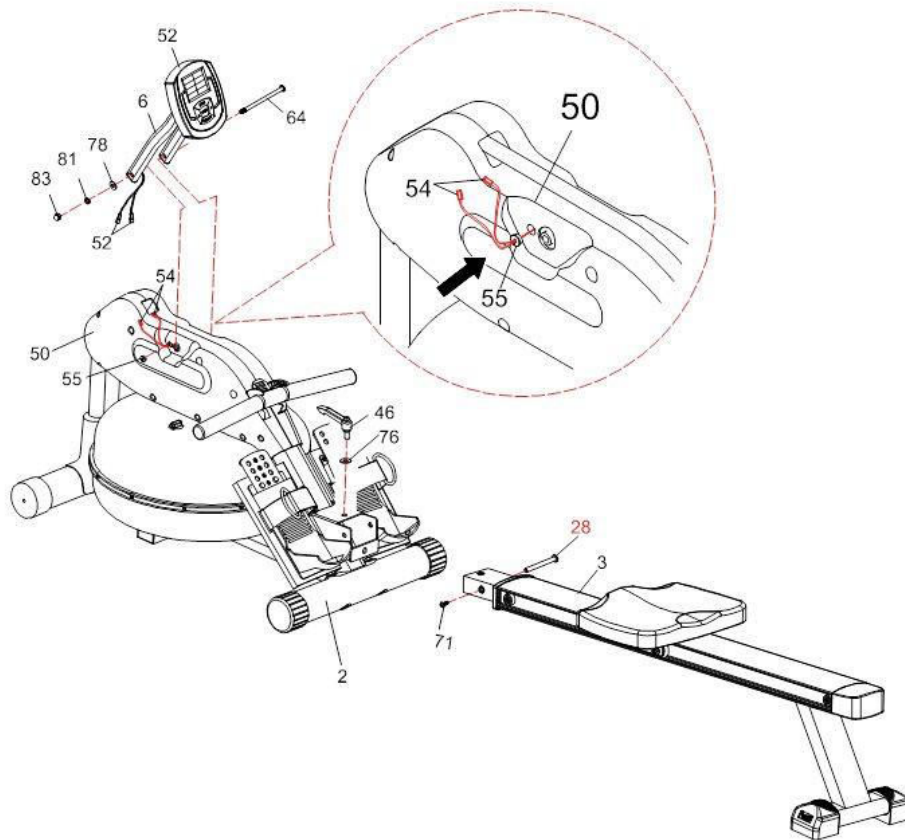

HOW TO FILL AND EMPTY THE TANK

1. Remove the fill plug (24) from the upper tank (17).
2. Refer to the A illustration to fill it with water. Insert the funnel (108) into the tank. Use a water cup or the syphon pump (107) and a bucket to fill the tank. Use a water level gauge on the side of the tank to measure desired water level (volume) in the tank.
3. Refer to the picture B to empty the tank. Place a bucket next to the rower. Use the syphon pump (107) to pump out the water from the tank into the bucket.
4. Once completed, insert the fill plug (24) into the upper tank (17). Wipe excess water out from the frame after filling.

NOTE:

- Fill the tank only with municipal water and don't use water from a well. If municipal water is not available, use distilled water and add water-purification tablet. Never use pool chlorine or chlorine bleach. More information in the maintenance section.
- Water from the tank is not suitable for human or animal consumption. Dispose the water after pumping it out from the tank.

WATER LEVEL

- Look at the Fig. A. The water level gauge is situated on the tank side. The max. filling level is: 10. Never fill it over this limit. Not observing it should void the warranty. The standard calibration level is: 9.
- The resistance depends on the water amount in the tank. For example, water level 3 offers a light resistance. Level 9 then means the highest resistance.

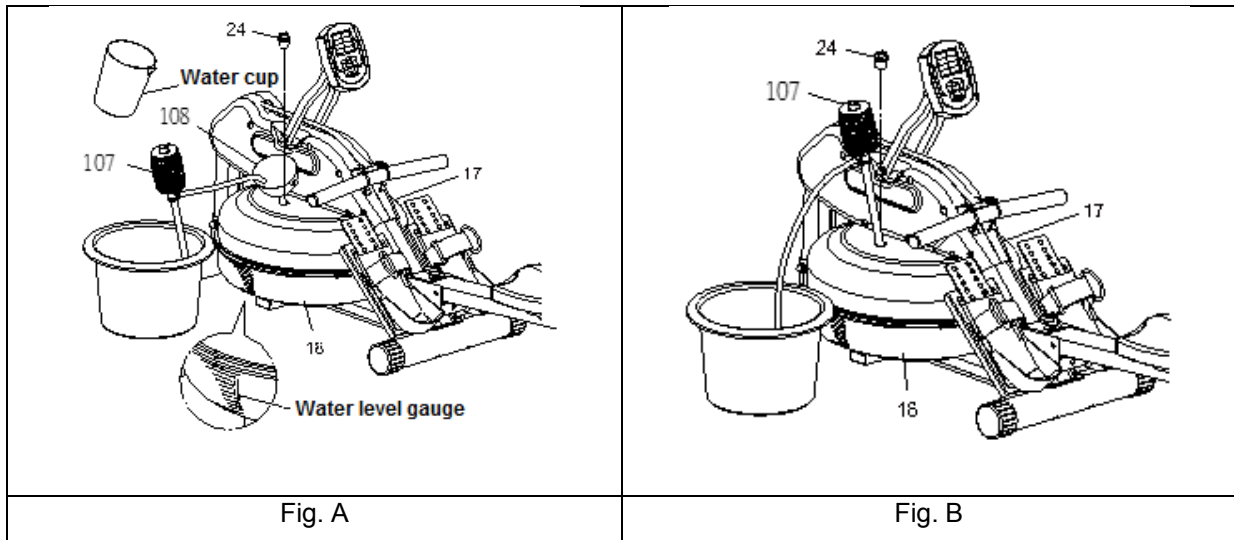

FITNESS METER

POWER ON: Move the handlebar or push any button.

POWER OFF: Its huts down automatically after 4 minutes of no activity.



BUTTON FUNCTIONS

MODE	<ul style="list-style-type: none"> Press and release it to select each function to pre-set target values of TIME, COUNT, DISTANCE, CALORIES, PULSE.
RESET	<ul style="list-style-type: none"> Push it in the SETTING mode to reset setting values to zero (TIME, COUNT, DISTANCE, CALORIES). The PULSE will be reset to 90. Push and hold it for 2 seconds to reset all functions to zero.
UP	<ul style="list-style-type: none"> It increases the setting values.
DOWN	<ul style="list-style-type: none"> It decreases the setting values.
RECOVERY	<ul style="list-style-type: none"> Push it to activate the pulse recovery function after a workout. You should wear a chest belt (optional) on your chest to measure the pulse.

FUNCTIONS

TIME	<ul style="list-style-type: none"> It displays the time from 1 sec. up to 99:59 mins. It can count down from a pre-set value.
COUNT	<ul style="list-style-type: none"> It displays the total number of rows that you have taken in range from 0 to 9999.
DISTANCE	<ul style="list-style-type: none"> It displays the distance from 0 to 99.9 km or counts down from a pre-set value.
CALORIES	<ul style="list-style-type: none"> It displays burned calories in range from 0 to 9999 kcal or counts down from a pre-set value. This value is only indicative without any medical validity. Use it only for comparison.
STROKES/MIN	<ul style="list-style-type: none"> It displays the rowing speed from 0 to 999 strokes per min.
PULSE	<ul style="list-style-type: none"> It displays the heart rate from 40 to 240 bpm. Wear an optional chest belt to use this function to assure a signal transmission between the belt and device receiver. Each heart rate signal will be accompanied with one flashing symbol "♥". If you don't attach the chest belt properly, "P" mark will be displayed. You can use UP, DOWN, RESET buttons to set in your target pulse value. During your exercising, the system warns you by an audio alarm if the target value has been reached or exceeded. Reduce your workout intensity gradually to keep your pulse in the target zone.
	Travel distance indicator – indicates the travel distance on the rowing machine during your workout.

PRESET VALUES

You can pull on the handlebar to power on the meter and work with the meter directly. Or it is possible to preset the function values for counting down. Stop rowing for four seconds, press MODE to enter the setting mode. The meter goes through input items as follows and allows you to set in the values. Use UP, DOWN and RESET keys to set them in. Push MODE to confirm it. Or just push MODE to skip the setting and move onto next function. After you have set in all desired values, pull the handlebar to start it.

Time	1:00 – 99:00
Count	10 – 9990
Distance	0.1 – 99.9 km
Calories	1.0 – 9999 kcal
Pulse	90 – 220 bpm

NOTE:

1. You can preset values for several functions. The preset function values will start counting down. When you complete one of the pre-set functions, the meter will remind you by an audio alarm for three seconds. Thereafter the value of the completed function will start counting up, whilst the other pre-set functions will continue to count down.
2. The meter will shut off automatically after 4 minutes without any activity. All function values will be kept. Push RESET key and hold it for 2 seconds to reset all functions to zero.

PULSE RECOVERY FUNCTION

NOTE: To use this program, you should wear the chest belt (optional) to your chest. The pulse recovery function measures how quickly you return to a resting heart rate after exercising. You can

use it to watch your improvement. The meter will monitor your heart rate for 60 seconds and calculate a pulse recovery value from 1 to 6:

1.0	Excellent
2.0	Good
3.0	Fair
4.0	Below Average
5.0	Not Good
6.0	Poor

- Use the values only for comparison among workouts.
- It can be used directly after an aerobic workout.
- Stop exercising before starting this function.

To start the pulse recovery function, your heart rate will be displayed for approx. 5 seconds after the heart symbol is displayed. Then push the RECOVERY button. During the pulse recovery function, only PULSE and TIME are working and will be displayed as shown in the picture A. Time will count down from 0:60 and the heart symbol will blink. When the time reaches zero, the meter will remind you with an audible signal for three seconds and shows your pulse recovery condition from 1.0 to 6.0. See the picture B. Push any button to exit from the pulse recovery function and switch to activity mode.

NOTE:

1. You can press the RECOVERY button at any time to run pulse recovery program, even during a workout.
2. Once the pulse recovery function has been started, the TIME will count down from 60 seconds to zero. You can press RESET key to quit the pulse recovery function. If no heart signal is available, a "P" mark will be displayed in the PULSE window. The "E" mark will be displayed in pulse recovery value window, if the TIME reaches zero.

A	
	1. Time
	2. The highest heart rate detected during the first 20 seconds.
	3. Current heart rate ("P" mark is displayed if a proper heart rate signal is not available)
B	
	1. Time
	2. Pulse recovery value
	3. The lowest heart rate detected during the pulse recovery running.
	4. End heart rate

BATTERY INSTALLATION AND REPLACING

1. Use your finger or a simple tool to remove the cover from the meter back.
2. The meter is powered by two batteries. Replace them as shown in picture.

NOTE:

- Don't mix new and older batteries.
- Use the same battery type. Don't mix alkaline batteries with another type.
- Dispose batteries according to local laws.
- Never put batteries in fire.

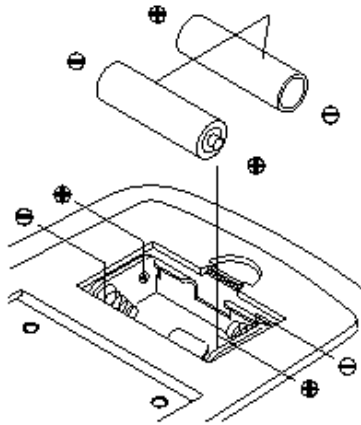

STORAGE

1. Store it in a clean and dry place.
2. If you store it for one year and longer, remove batterie.
3. To move it, use moving wheel end cap (26) on the front of the base frame (1). Catch the rear stand (4) to transport it. Never use the seat (31) to transport it. The seat could slide and its carriage could crush your fingers.
4. If you store it for longer than one month, empty the water tank.
5. Fold it as shown in pictures below:
 - Remove the fixing lever (46) and washer (76) from the main frame (2).
 - Fold the rail (3) and lock in the folded position using the fixing lever (46) and washer (76). Make sure the rail (3) is properly secured and doesn't drop down.

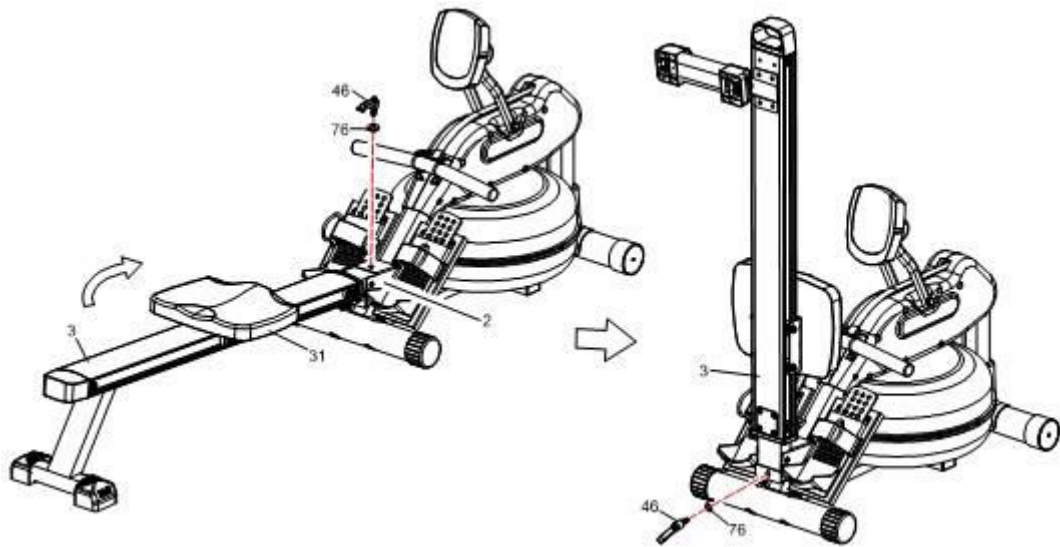

MAINTENANCE

This machine can assure user safety only if it is without fault or wearing. Maintain it regularly to assure your safety. Check it regularly for damage and wearing. Never use damaged or worn product.

- Sit on the seat (31) and pull on the handlebar (8) to make sure the water system offers adequate resistance and the seat moves smoothly and steadily.
- Periodically maintain water in the tank. Refresh it periodically by adding a water purification tablet, such as sodium dichlor (56% chlorine) every 4-6 months. **WARNING!** Never use pool chlorine (Trichlor 90% chlorine) or a chlorine bleach. It could damage this product and void the warranty.
- Clean the roller track on the rail (3) with an absorbent cloth.
- Clean the tank periodically. Never use methylated spirits, chlorates, bleach or ammonia based cleaners. It could damage this product and void the warranty.
- User/owner is responsible for proper maintaining.
- Damaged or worn parts should be replaced immediately. To repair it, contact a service.
- Only supplied and original spare parts should be used for repairing or maintenance.
- After each usage wipe it using an absorbent cloth.

EXERCISE GUIDE

Rowing is an extremely effective form of exercising. It strengthens your heart and improves blood circulation as well. There are involved all major muscle groups of back, waist, arms, shoulders, hips and legs.

BASIC ROWING STROKE

Sit on the saddle and fasten your feet to the pedals using Velcro straps. Then take hold of the rowing bar. Take the start position, lean forward with your arms straight and knees bent as shown in Fig. 1. Push your body backwards while simultaneously straightening your back and legs (Fig. 2). Continue this movement until you are leaning slightly backwards. Bring your arms out of the side during this phase (Fig. 3). Thereafter return to the second position and repeat it as shown below.

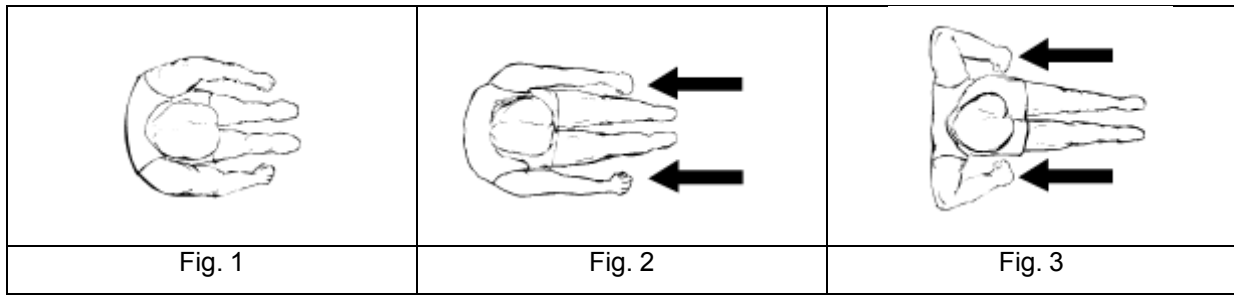

TRAINING TIME

Rowing is a strenuous training style. Because of it, is better to start with a short and easy program and continue to a longer and intensive workout. Start rowing for about 5 minutes and increase the workout length gradually to improve your fitness. Finally, you should be able to row for 15-20 mins. Don't try to do it too quickly. Try to train on alternate days, 3 times a week. Take a recovery time between workouts.

ROWING STYLE ALTERNATION

ONLY ARM ROWING: This workout should tone your arm, shoulder, back and abdominal muscles. Sit on the machine as shown in Fig. 4. Straight your legs, lean forward and grasp the handles. Control your moving and gradually lean back to just past the up-right position (Fig. 5) and continue to pull the handles towards your chest (Fig. 6). Return to the starting position and repeat.

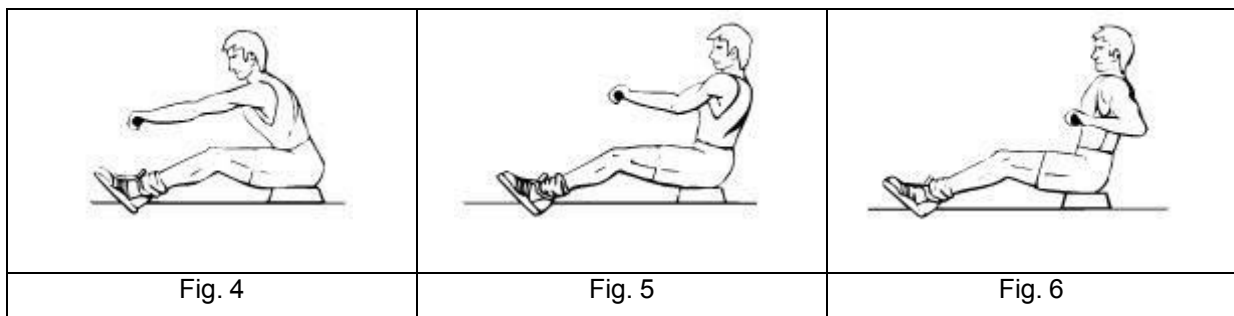

ONLY LEG ROWING: This workout helps toning your leg and back muscles. Keep your back straight and arms out-stretched, bend your legs until you will grasp the rowing handles in the starting position (Fig. 7). Use your legs to push your body back (Fig. 8) while keeping your arms and back straight as shown in Fig. 9.

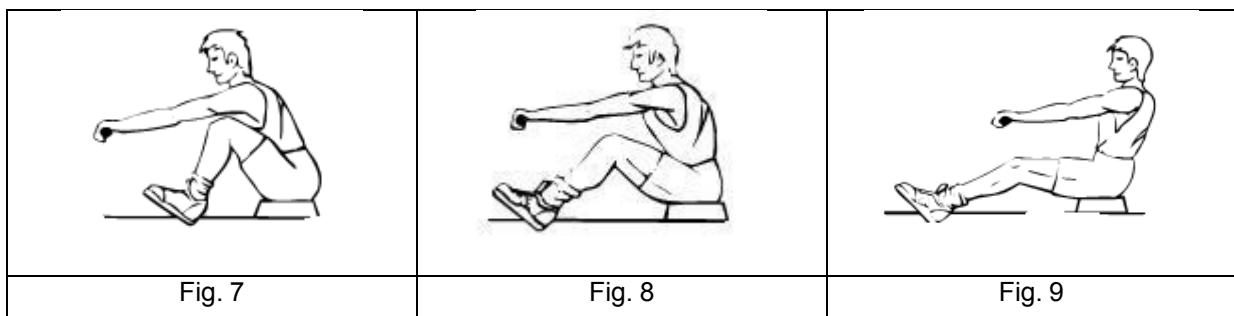





EXERCISE INSTRUCTIONS

Using this device provides you with several benefits such as better physical fitness, toned muscles and, in combination with controlled diet, weight loss.

1. WARM-UP PHASE

This phase should help improving blood circulation and make your muscles working properly while reducing a cramp risk or injury. It is advisable to do a few stretching exercises as shown below. Each stretching exercise should be taken for approx. 30 seconds. Don't overstretch and don't jerk your muscles. If you feel pain, stop immediately.

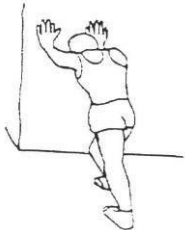
	Side bends
	Forward bends
	Outer thigh
	Inner thigh
	Calves and Achilles tendon

2. EXERCISE PHASE

It is a phase, during which you should put in your effort. After regular workout, your leg muscles should get more flexible. Keep steady tempo throughout your exercising. The workout intensity should be sufficient to raise your heartbeat into the target zone as shown below.

NOTE: This stage should last for at least 12 mins. Thus, most people start at approx. 15-20 mins.

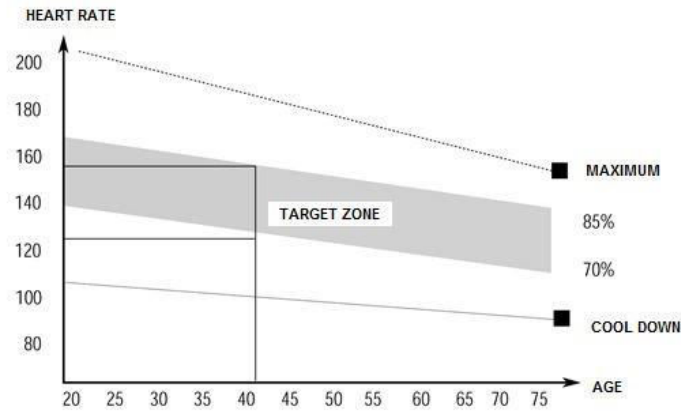

3. COOL-DOWN PHASE

In this stage, your cardio-vascular system and muscles should get calm. Repeat the warm-up exercises, reduce your tempo and continue for approx. 5 mins. Repeat the stretching exercises, but don't overstretch or jerk your muscles. As you get fitter, you can exercise longer and harder. It is advisable to train at least three times a week and, if possible, to space your workouts evenly throughout a week.

MUSCLE TONING

To tone muscle while on your revolution device, you will need to have the resistance set quite high. This will put more strain on our leg muscles and may mean you cannot train for as long as you would like. If you are also trying to improve your fitness, you need to alter your training program. You should train as normal during the warm-up and cool-down phases, but towards the end of the exercise phase you should increase resistance making your legs work harder. You will have to reduce your speed to keep your heart rate in the target zone.

WEIGHT LOSS

The important factor here is the amount of effort you put in. The harder and longer you work the more calories you will burn. Effectively this is the same as if you were training to improve your fitness, the difference is the goal.

ENVIRONMENT PROTECTION

After the product lifespan expired or if the possible repairing is uneconomic, dispose it according to the local laws and environmentally friendly in the nearest scrapyard.

By proper disposal you will protect the environment and natural sources. Moreover, you can help protect human health. If you are not sure in correct disposing, ask local authorities to avoid law violation or sanctions.

Don't put the batteries among house waste but hand them in to the recycling place.

TERMS AND CONDITIONS OF WARRANTY, WARRANTY CLAIMS

General Conditions of Warranty and Definition of Terms

All Warranty Conditions stated hereunder determine Warranty Coverage and Warranty Claim Procedure. Conditions of Warranty and Warranty Claims are governed by Act No. 40/1964 Coll. Civil Code, Act No. 513/1991 Coll., Commercial Code, and Act No. 634/1992 Coll., Consumer Protection Act, as amended, also in cases that are not specified by these Warranty rules.

The seller is SEVEN SPORT s.r.o. with its registered office in Borivojova Street 35/878, Prague 13000, Company Registration Number: 26847264, registered in the Trade Register at Regional Court in Prague, Section C, Insert No. 116888.

According to valid legal regulations it depends whether the Buyer is the End Customer or not.

“The Buyer who is the End Customer” or simply the “End Customer” is the legal entity that does not conclude and execute the Contract in order to run or promote his own trade or business activities.

“The Buyer who is not the End Customer” is a Businessman that buys Goods or uses services for the purpose of using the Goods or services for his own business activities. The Buyer conforms to the General Purchase Agreement and business conditions to the extent specified in the Commercial Code.

These Conditions of Warranty and Warranty Claims are an integral part of every Purchase Agreement made between the Seller and the Buyer. All Warranty Conditions are valid and binding, unless otherwise specified in the Purchase Agreement, in the Amendment to this Contract or in another written agreement.

Warranty Conditions

Warranty Period

The Seller provides the Buyer a 24 months Warranty for Goods Quality, unless otherwise specified in the Certificate of Warranty, Invoice, Bill of Delivery or other documents related to the Goods. The legal warranty period provided to the Consumer is not affected.

By the Warranty for Goods Quality, the Seller guarantees that the delivered Goods shall be, for a certain period of time, suitable for regular or contracted use, and that the Goods shall maintain its regular or contracted features.

The Warranty does not cover defects resulting from (if applicable):

- User's fault, i.e. product damage caused by unqualified repair work, improper assembly, insufficient insertion of seat post into frame, insufficient tightening of pedals and cranks
- Improper maintenance
- Mechanical damages
- Regular use (e.g. wearing out of rubber and plastic parts, moving mechanisms, joints etc.)
- Unavoidable event, natural disaster
- Adjustments made by unqualified person
- Improper maintenance, improper placement, damages caused by low or high temperature, water, inappropriate pressure, shocks, intentional changes in design or construction etc.

Warranty Claim Procedure

The Buyer is obliged to check the Goods delivered by the Seller immediately after taking the responsibility for the Goods and its damages, i.e. immediately after its delivery. The Buyer must check the Goods so that he discovers all the defects that can be discovered by such check.

When making a Warranty Claim the Buyer is obliged, on request of the Seller, to prove the purchase and validity of the claim by the Invoice or Bill of Delivery that includes the product's serial number, or eventually by the documents without the serial number. If the Buyer does not prove the validity of the Warranty Claim by these documents, the Seller has the right to reject the Warranty Claim.

If the Buyer gives notice of a defect that is not covered by the Warranty (e.g. in the case that the Warranty Conditions were not fulfilled or in the case of reporting the defect by mistake etc.), the Seller is eligible to require a compensation for all the costs arising from the repair. The cost shall be calculated according to the valid price list of services and transport costs.

If the Seller finds out (by testing) that the product is not damaged, the Warranty Claim is not accepted. The Seller reserves the right to claim a compensation for costs arising from the false Warranty Claim.

In case the Buyer makes a claim about the Goods that is legally covered by the Warranty provided by the Seller, the Seller shall fix the reported defects by means of repair or by the exchange of the

damaged part or product for a new one. Based on the agreement of the Buyer, the Seller has the right to exchange the defected Goods for a fully compatible Goods of the same or better technical characteristics. The Seller is entitled to choose the form of the Warranty Claim Procedures described in this paragraph.

The Seller shall settle the Warranty Claim within 30 days after the delivery of the defective Goods, unless a longer period has been agreed upon. The day when the repaired or exchanged Goods is handed over to the Buyer is considered to be the day of the Warranty Claim settlement. When the Seller is not able to settle the Warranty Claim within the agreed period due to the specific nature of the Goods defect, he and the Buyer shall make an agreement about an alternative solution. In case such agreement is not made, the Seller is obliged to provide the Buyer with a financial compensation in the form of a refund.



Office:	Русе, ул. "ТЕЦ Изток" 20
Phone:	070080020 / 09897612190
E-mail:	office@yako.bg
Web:	www.insportline.bg