

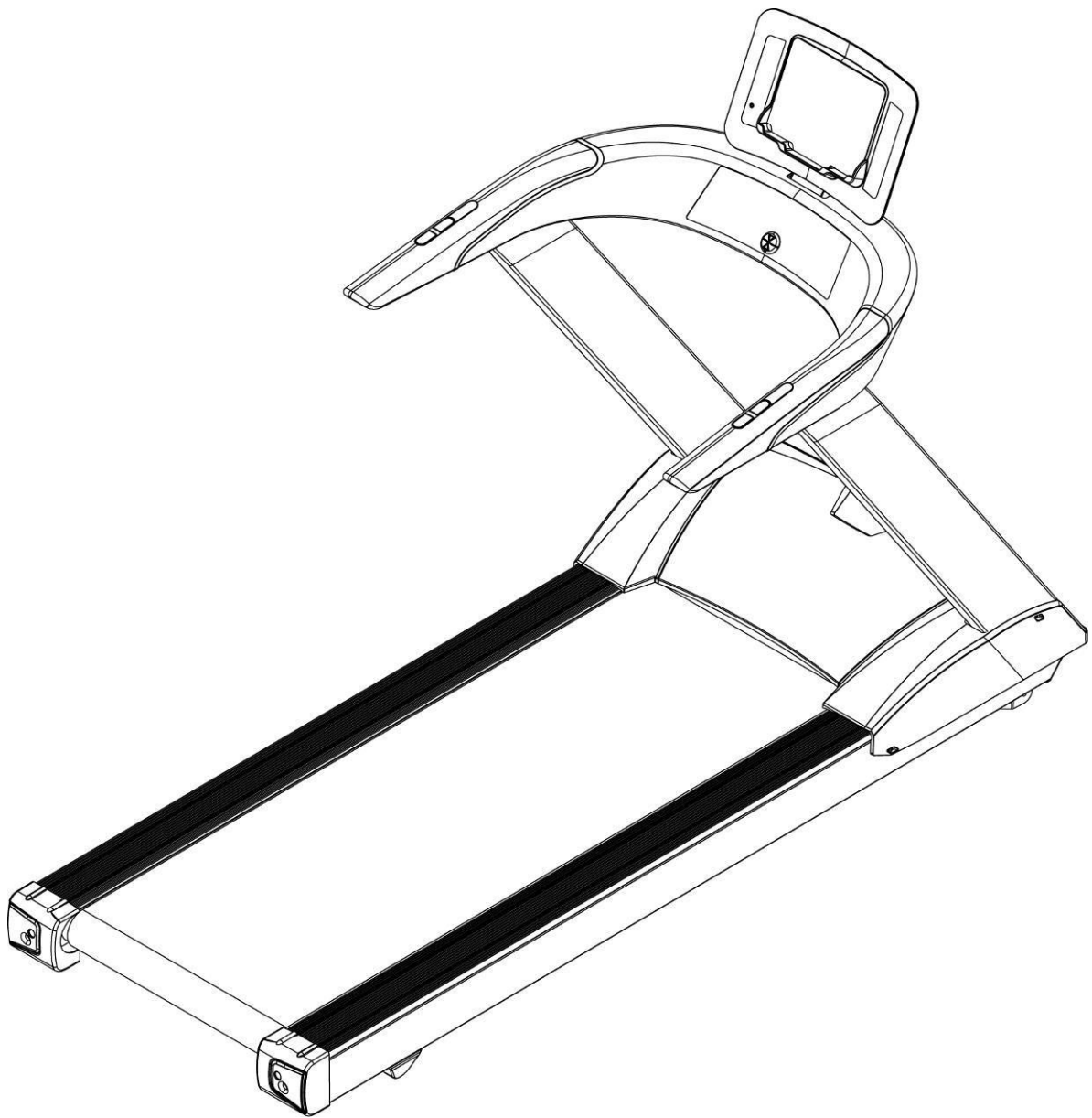

USER MANUAL – EN
IN 6079 Treadmill inSPORTline Borra



CONTENTS

1.	OUTLOOK INSTRUCTION	3
2.	SAFETY INSTRUCTION	3
3.	WAY OF TREADMILL USING	5
4.	GROUNDING WIRES INSTRUCTIONS	5
5.	ASSEMBLE PART LIST	6
6.	ASSEMBLE STEPS	7
7.	MAINTENANCE	9
8.	ADD SILICONE	10
9.	CONSOLE HANDLE INSTRUCTION	12
9.1	LCD Decal	13
9.2	Heart Rate Training Zone Instruction	13
9.3	Body Muscle Instruction	13
9.4	Main Keyboard Instruction	14
9.5	Handrail Keyboard Instruction	15
9.6	Heart Rate Instruction	15
9.7	Program Simple Handle Instruction	16
9.8	APP (iOS&Andriod) INSTALLATION GUIDANCE	22
10.	PARTS LIST.....	33
11.	EXPLODED VIEW	38
12.	ATTACHMENT	39
13.	TERMS AND CONDITIONS OF WARRANTY, WARRANTY CLAIMS	42

1. OUTLOOK INSTRUCTION

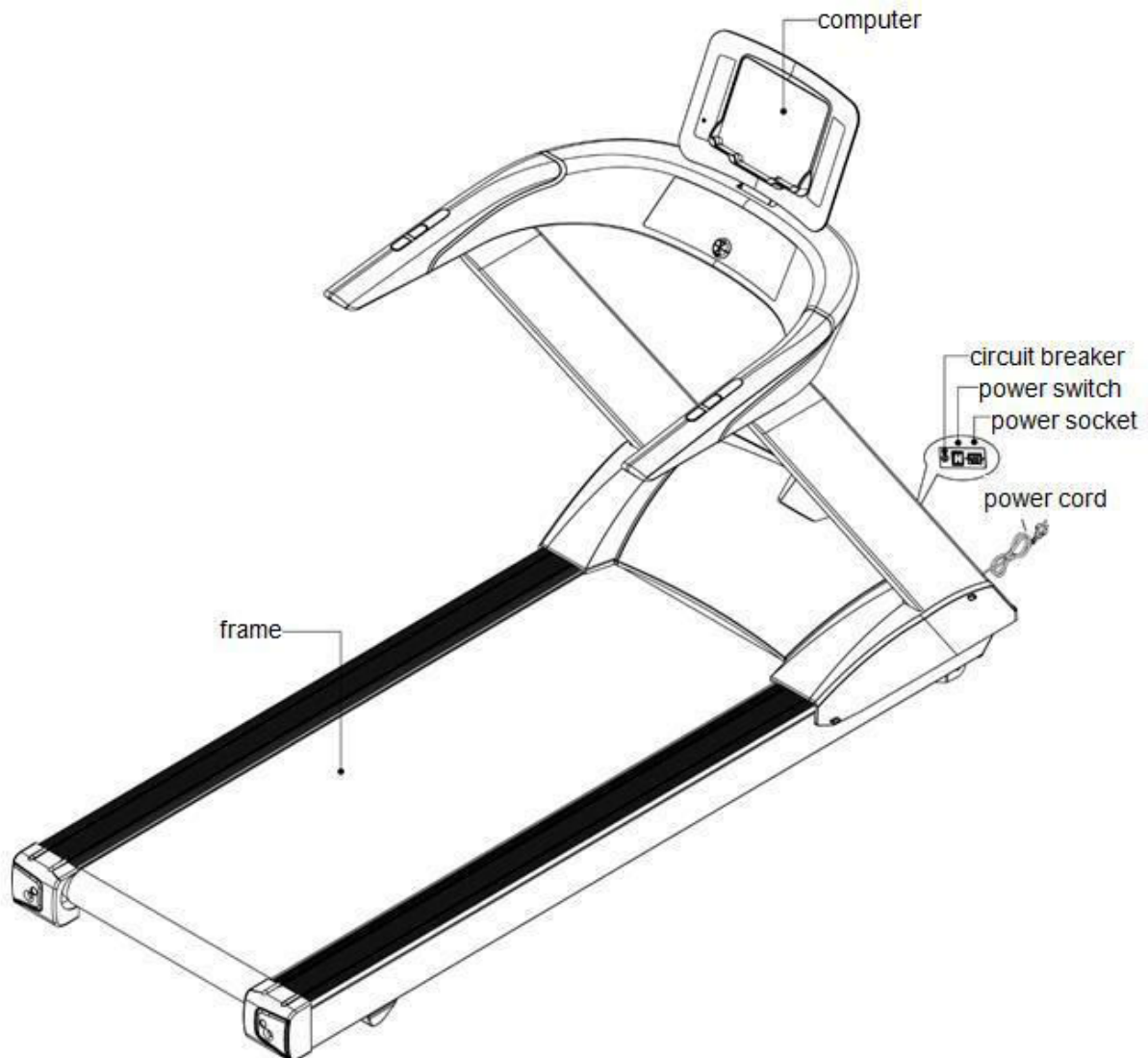

2. SAFETY INSTRUCTION

When using this product, basic precautions should always be followed, including the following:
Please read the instruction carefully before starting to use this product.

- **DANGER – To reduce the risk of electric shock:**

Always unplug this product from the electrical outlet immediately after using and before cleaning.

- **WARNING – To reduce the risk of burns, fire, electric shock, or physical injury:**

1. The product should never be left unattended while plugged in. Unplug the product from the outlet when not in use.
2. Close supervision is necessary when this product is used by or near children, invalids, or disabled persons.

3. Be sure to use the product only for its intended use as described in this manual. Do not use any attachment not recommended by the manufacturer in order to avoid any danger or accidents.
4. Never operate the product if it has a damaged cord or plug, if it is not working properly, if it has been damaged, or dropped into water. Please return the product to the service center of seller for examination and repair.
5. Do not carry this product by the supply cord or use the cord as a handle.
6. Keep the cord away from hot surfaces or ground.
7. Never operate the product with the air vents blocked. Keep the air vents free of lint, hair, etc.
8. Never drop or insert any objects into any openings.
9. Do not use or operate outdoors.
10. Do not operate where aerosol (spray) products are being used or where oxygen is thin.
11. Before turning the product power off, turn all controls to the off position then remove the plug from the outlet.
12. Connect the product to a properly grounded outlet only.
13. If the power cord is damaged, be sure to ask the manufacturer for replacement to avoid accidents. The seller and correlative qualified professionals are as well as eligible.
14. This appliance is not intended for use by persons (including children) with reduced physical, sensory or mental capabilities, or lack of experience and knowledge, unless they have been given supervision or instruction concerning use of the appliance by a person responsible for their safety. Children should be supervised to ensure that they do not play with the appliance.
15. Incorrect or excessive training may cause injuries t health may results.
16. The equipment shall be installed on stable base and properly leveled.
17. A shall be safety area of 2,000mm x 1,000mm behind the equipment.
18. Maximum user weight is 180 Kgs.
19. If this treadmill can be folded, please return the elevation to the original position after using.
20. When this treadmill is being used, it cannot be folded at the same time. Required to confirm the device completely stopped before folding.
21. The safety level of the equipment can be maintained only if it is examined regularly for damage and wear.
22. Any of the adjustment devices that could interfere with the user's movement should not be left projecting.
23. Users correct ergonomic position on the equipment shown in Figure

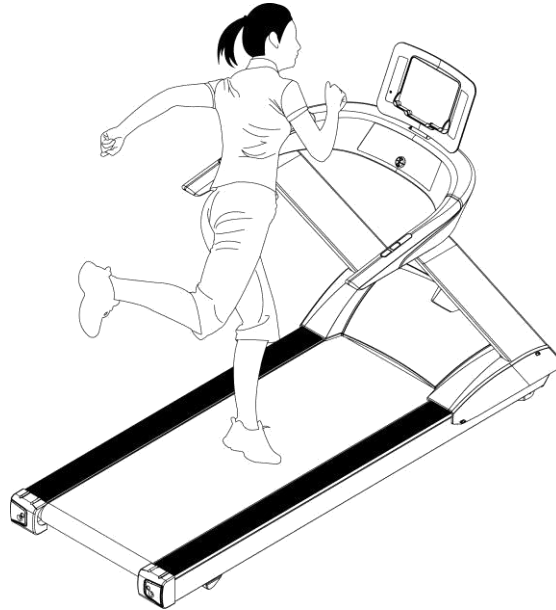

24. Before using this product, you should step on the it then turn on the product. Do not turn on the treadmill before step on it.
25. Running surface Width dimensions 550*1525mm
26. Class - SA (according to EN ISO 20957) for commercial use.
27. **WARNING!** A system for monitoring heart rate may not be accurate. Overloading during training may cause serious injury or death. If you feel any discomfort, immediately stop the exercise!
 - **Caution: Be sure incline has back to 0 before folding.**

3. WAY OF TREADMILL USING

When you want to use treadmill, please do not stand on running belt. Before start treadmill, please make it powered and grip the handrail to stand on pedal of treadmill's two side, then press "START" and wait for the motor work at a lower speed, stand on the center of running area to run. Remember clip the safety clip on waist to avoid fall down and it can make the treadmill stop at once. Please do not take quick speed to start the treadmill and jump on treadmill. When in emergency, please grip the handrail or the front handrail and jump on pedal.

4. GROUNDING WIRES INSTRUCTIONS

1. The products must be grounded first. If malfunction or breakdown occurs, grounding will provide a path of least resistance for electric current to reduce the risk of electric shock.
2. The product is equipped with a cord having an equipment-grounding conductor and a grounding plug.
3. The plug must be plugged into an appropriate outlet that is properly installed and grounded in accordance with all local codes and ordinances.
 - **Danger – Improper connection of the equipment-grounding conductor can result in a risk of electric shock. Check with a qualified electrician or serviceman if you doubt whether the products are properly grounded. Do not modify the plug provided with the product – if it will not fit the outlet, have a proper outlet install by a qualified electrician.**
4. The products is for use on normal 220V–240V and has circuit and contains a plug that looks like the one illustrated in the figure. Make sure that the product is connected to an outlet having the same configuration as the plug.

5. No adapter should be used with the product.

Figure
Grounding methods

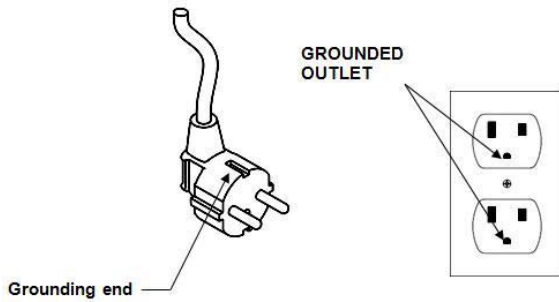

5. ASSEMBLE PART LIST

Instruction for parts of product:

	<p>This treadmill also can use other way to account the HRC. When in fitness, user can wear the chest pulse belt and the HRC will show in Pulse windows.</p>
--	--

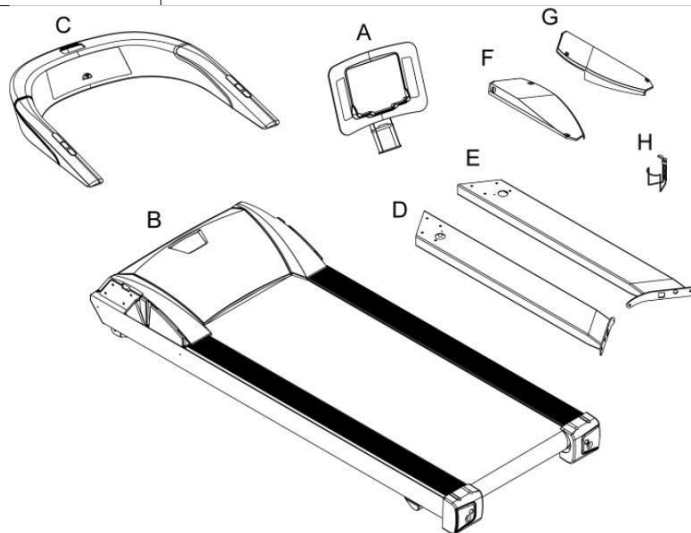

ITEM	Description	Qty
A	Computer console with fixing shelf	1
B	Frame	1
C	Computer handrail tube set	1
D	Left upright tube	1
E	Right upright tube	1
F	Left sidecover	1
G	Right sidecover	1
H	Flask shelf	1

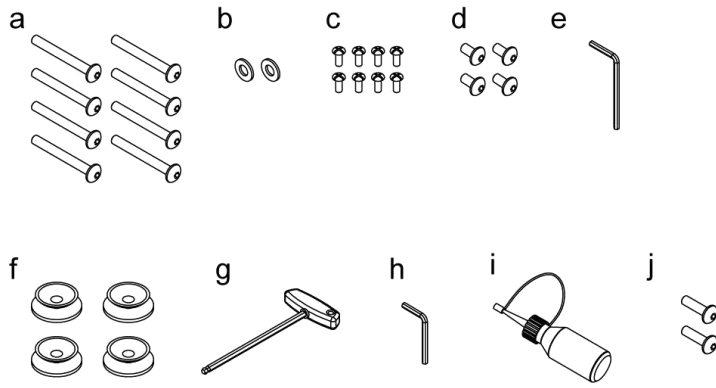

ITEM	Description	Qty
a	Truss hex screw M8xP1.25x75	8
b	Spring washer M8	2
c	Truss philips screw M5xP0.8x15	8
d	Truss hex screw M8xP1.25x15	4
e	Hex Wrench 6mm x 80mm x 80mm	1
f	Sucker	4
g	T shaped wrench 8mm x 200mm	1
h	Hex Wrech + Screwdriver 5mm x 70mm x70mm	1
i	SILICONE	1
j	Truss hex screw M8xP1.25x30	2

6. ASSEMBLE STEPS

STEP 1

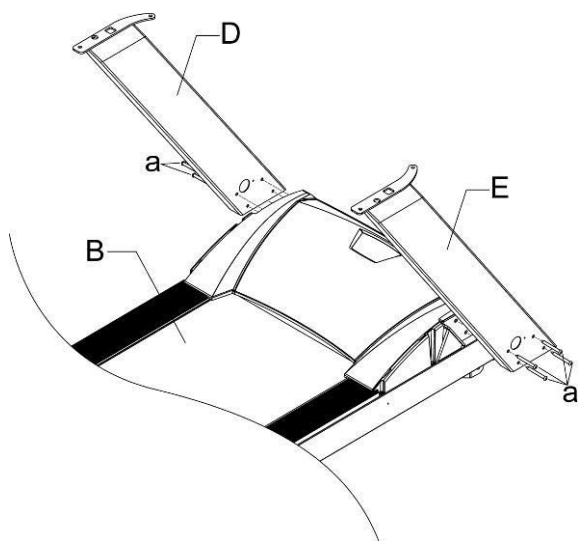

P.S.To avoid being in dangerous, need two person or more to do assembly.

Fix the left & right upright tube(D,E) on fame(B) with screw(a), but not fasten.

STEP 2

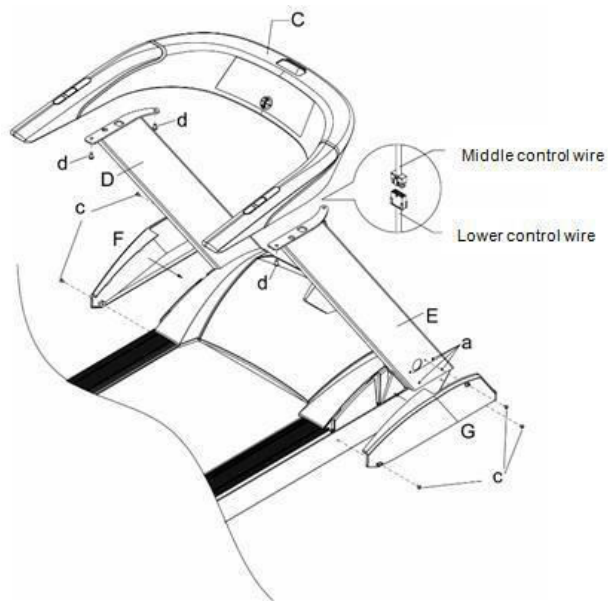

Put computer handrail tube(C) on upright tube, after connecting lower control wire and middle control wire, lower TV cable wire and middle TV cable wire, then fix with screw(d) and fasten with screw(a).After finished, fasten left &right side cover with screw(c).

STEP 3

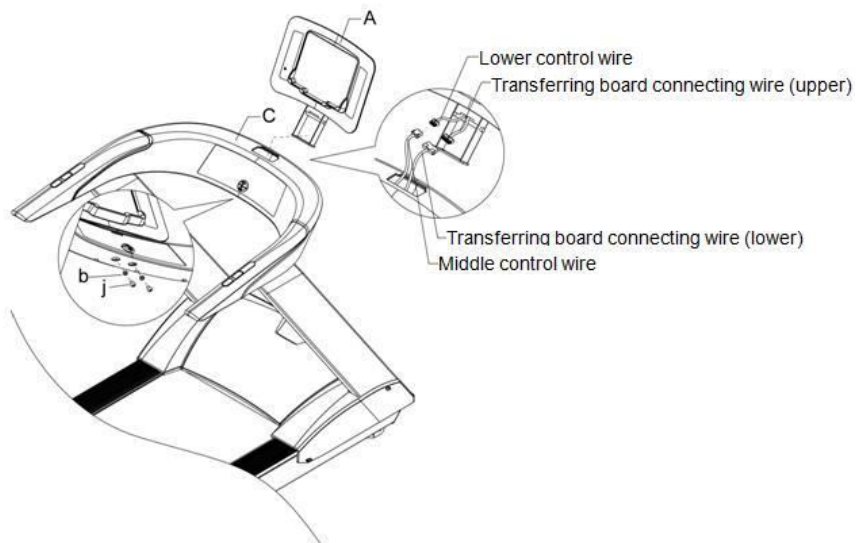

Put console that with fixing shelf (A) on computer handrail tube(C), then connect control wire, TV cable wire & transferring board wire well by turn and put the extra wires in computer fixing shelf, put computer in handrail set and fasten with screw (j) & spring washer (b).

STEP 4

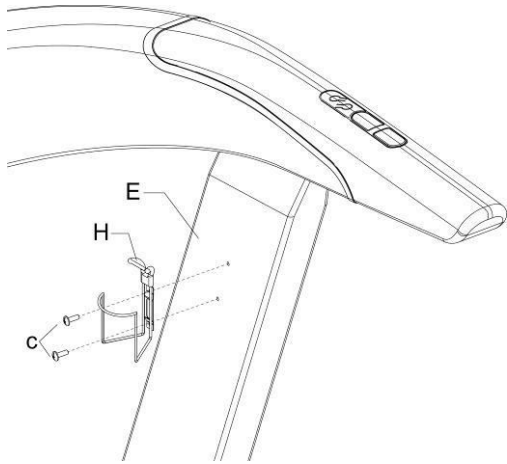

Pot Holder assembly:

Put Tea Pot Holder (H) on the Up Right Bar (E), secure the Bolt (c) inserted and fixed with fastening. **STEP 5**

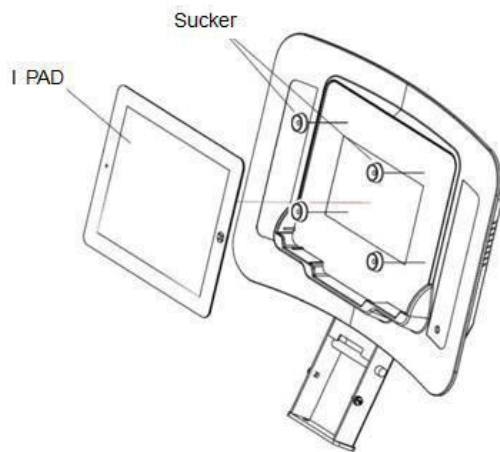

When you want to use I PAD, you can take out the sucker attached in parts package and stick it on the suitable place of computer(as left figure), then put your I PAD on supporter and use sucker to suck up your I PAD to avoid the I PAD falling down.

7. MAINTENANCE

If the belt tends to move off from the center, stop the treadmill. Use the Hex Wrench to adjust the Hex Screw in the Rear End Cap. For example, if the running belt is moving towards the left side, tighten the left Hex Screw about 1/4 turn (clockwise). If the running belt is moving towards the right side, tighten the right Hex Screw about 1/4 turn (clockwise). Turn on the treadmill after it has been adjusted. If you find that the belt has not moved to the proper position, please repeat the steps above. Don't use the treadmill until the running belt returns to the center position.

- This procedure is very important, if the belt is not in the center, be sure to follow

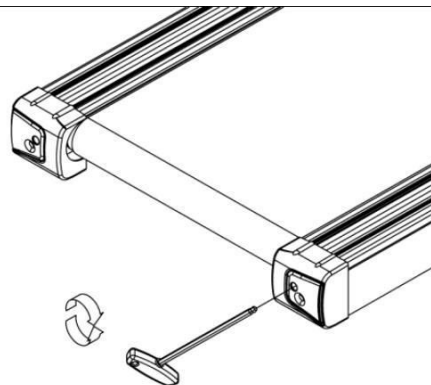

the above steps.

- The position of running belt might not stay precisely in the center with slightly towards the left and right sides, and the situation varies with how end-users use and the weight of end-users. No need to adjust the belt if it doesn't rub against the parts aside.

Depending on the usage of the product, please apply SILICON on the board according to the chart below. Use the Hex Wrench to unscrew the bolt inside the Rear Roller. Then pull the belt up and daub some SILICON to the center of the board. After that, adjust the belt to the center of the deck, followed by tightening the screw to the original set.

When the belt is sliding, please follow the method above to lubricate the running belt.

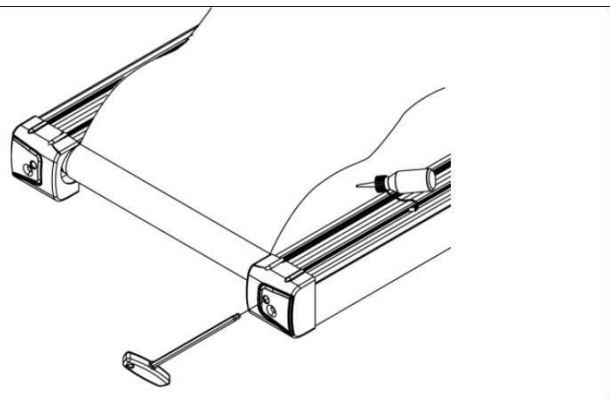

Speed and Maintenance Interval

Unit	Operating Speed	Recommended Lubrication Period
Metric Unit	6KM/hr below	1 year
	6~12KM/hr	6 months
	12KM/hr above	3 months
English Unit	4mile/hr below	1 year
	4~8mile/hr	6 months
	8mile/hr above	3 months
Remark: The maintenance interval is only intended for household use. If used for commerce, it is suggested to check the treadmill every month.		

8. ADD SILICONE

- Time of add SILICONE**

When suggested time of adding SILICONE is achieved, please extend your hand to the center of the running board to make sure whether there is any SILICONE before adding. If no SILICONE on the running board, please add 30cc SILICONE to the running board. If there is still a little SILICONE, add 15cc SILICONE to the running board.

- Area of adding SILICONE**

Add SILICONE from the center of the running board to the running belt 's the left and right side which should minus 6 cm.

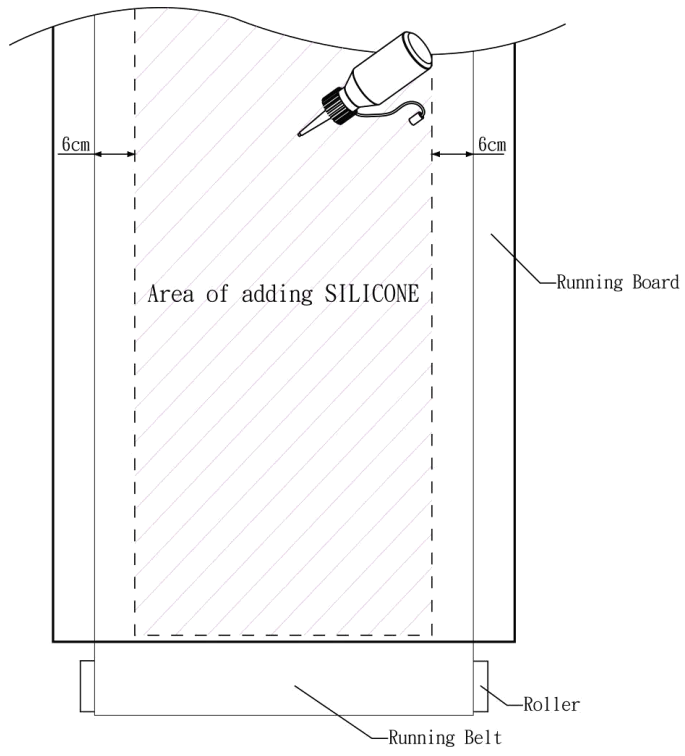

9. CONSOLE HANDLE INSTRUCTION

OPERATING INSTRUCTIONS

Turn on power switch and ensure the safety key is attached to console.
Attach safety clip to clothing before start up.

- To START**
For QUICK START press  key.
  keys to control speed.
- To end**
Decrease speed and press  key.

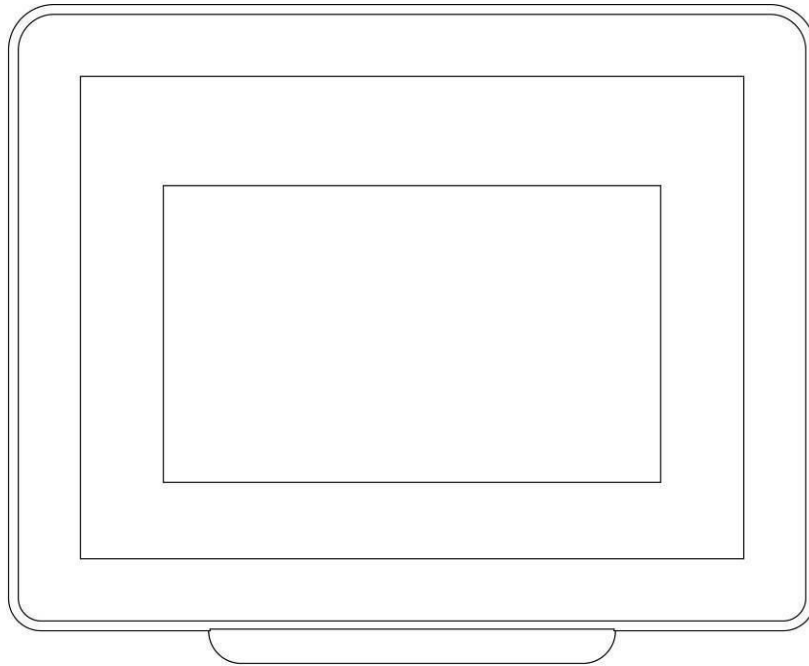

CAUTION
For your safety, please consult owner's manual carefully before using. Risk of injury to persons--To avoid injury, stand on the siderails before starting treadmill.

WARNING
Remove safety key when not in use and store out of reach of children.

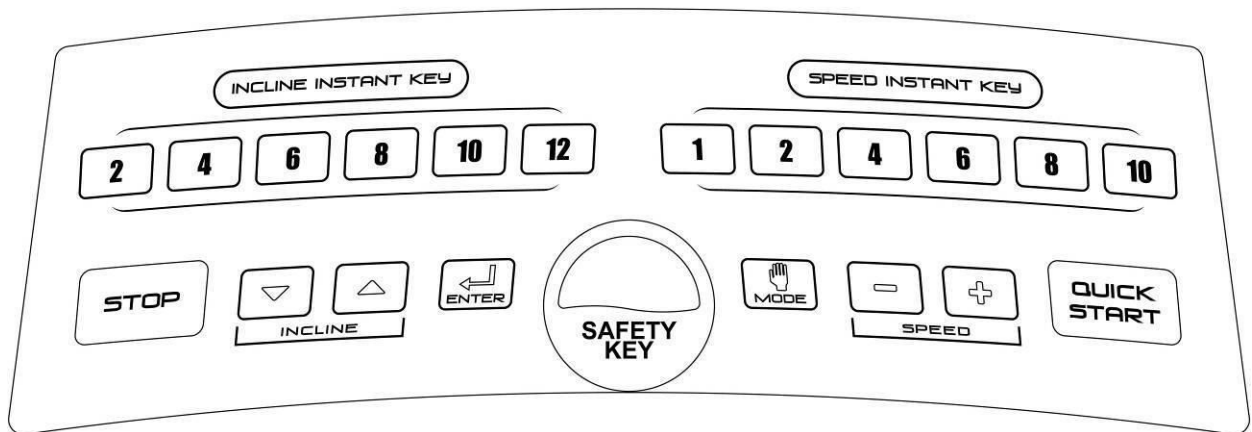

9.1 LCD Decal

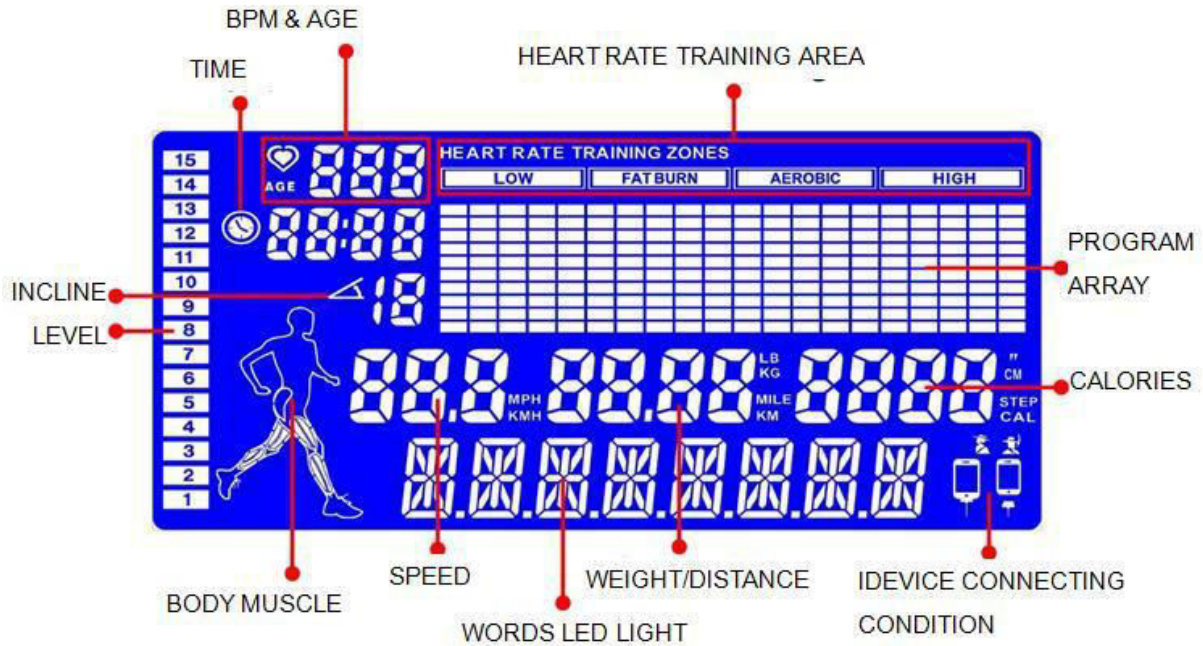

9.2 Heart Rate Training Zone Instruction



User in this age range, goal HRC formula: Max. heart rate = (220 - age) .

Low: 0~64%

Fatburn: 65%~74%

Aerobic: 75%~84%

High: 85% above

Instruction: If user is 30 years, the max HRC is below 190, in HRC training mode, if user HRC is 120, so $120/190 = 63\%$ and it will show Low.

9.3 Body Muscle Instruction

When the treadmill starts, body and muscle lines will light, when user adjust Incline, the corresponding muscle training will flash.

0 level	1~3 levels	4~6 levels
7~9 levels	10~12 levels	13~15 levels

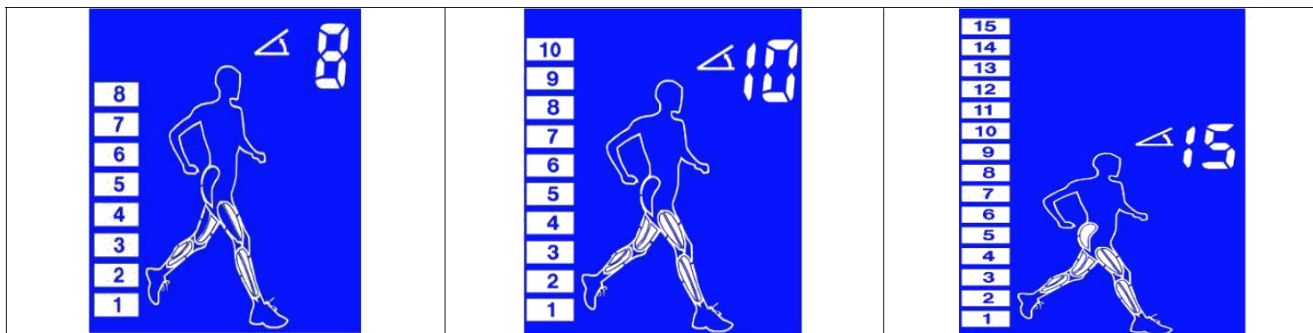

9.4 Main Keyboard Instruction



START:

- a) After start, press this key can enter quick fitness training.
- b) During PAUSE, press this key enter to start mode.

STOP:

- 1) During fitness, press this key will enter PAUSE condition. Windows will show "PAUSE", the pause time's preset value is 4 minutes. When the time is over 4 minutes systems will back to standby mode and screen will close the background light.
- 2) During PAUSE, press this key for 4 seconds, the training will stop and enter standby mode.
- 3) In selecting list mode, press this key can back to the upper list.

SPEED +/-: Press this key can adjust the treadmill's speed, 0.1 per time. If you press for a long time, the value will change fast.

INCLINE↑/↓: Press this key can adjust the treadmill's incline, 1 per time. If you press for a long time, the value will change fast.

ENTER: Press this key as a confirmation and enter next step.

MODE: During start/ready status, Press this key for Program circles setting

SPEED INSTANT KEY 1/2/4/6/8/10: Adjust treadmill speed to showing value directly, the unit is "KPH(MPH)".

INCLINE INSTANT KEY 2/4/6/8/10/12:Incline quick key, adjust incline to showing value directly, the unit is "°"

During fitness or standby mode, take off the SAFETY KEY, the center windows will show "DOWN ARROW" picture, and every value will show the original value"0". The treadmill motor and program will stop at once and incline stay at the angle before taking the safety clip. User need to put the safety clip back and treadmill can be used again, but the windows will auto back the resetting pages

9.5 Handrail Keyboard Instruction



- SPEED +/-: Press this key can adjust the speed, 0.1 per time. If you press for a long time, the value will change fast.
- INCLINE \uparrow/\downarrow : Press this key can adjust the treadmill's incline, 1 per time. If you press for a long time, the value will change fast.

9.6 Heart Rate Instruction



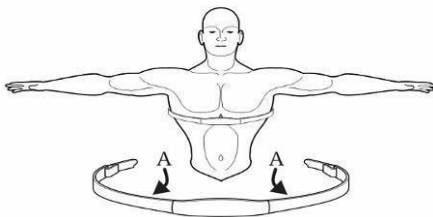



- Hand grip pulse: During fitness, if user grips the detector, you will see the heart rate windows' pulse picture flash, it means HRC detecting, it will show the actual HRC within 20 seconds.
- Wireless pulse receiver: For safety and correct sensor, when the speed over 7.2KPH (4.5MPH), advise to use chest belt pulse emitter instead of handgrip sensor. This is to use the way of wireless sensor, it will transport the pulse to the systems directly. Belt the chest belt pulse emitter under the chest muscle is better and have a little tighten, but can breath easy.



- Chest belt is not the necessary parts, user can buy it if need.
- HRC normal range is40~220BPM, when user use hand grip and wireless pulse emitter, please take the wireless pulse emitter's value as first.

Age	BPM			Age	BPM			Age	BPM			Age	BPM		
	H	Preset	L		H	Preset	L		H	Preset	L		H	Preset	L
13	197	124	124	31	180	113	113	49	162	103	103	67	145	92	92
14	196	124	124	32	179	113	113	50	162	102	102	68	144	91	91
15	195	123	123	33	178	112	112	51	161	101	101	69	143	91	91
16	194	122	122	34	177	112	112	52	160	101	101	70	143	90	90
17	193	122	122	35	176	111	111	53	159	100	100	71	142	90	89
18	192	121	121	36	175	110	110	54	158	100	100	72	141	90	89
19	191	121	121	37	174	110	110	55	157	99	99	73	140	90	88
20	190	120	120	38	173	109	109	56	156	98	98	74	139	90	88
21	189	119	119	39	172	109	109	57	155	98	98	75	138	90	87
22	188	119	119	40	171	108	108	58	154	97	97	76	137	90	86
23	187	118	118	41	170	107	107	59	153	97	97	77	136	90	86
24	186	118	118	42	169	107	107	60	152	96	96	78	135	90	85
25	185	117	117	43	168	106	106	61	151	95	95	79	134	90	85
26	184	116	116	44	167	106	106	62	150	95	95	80	133	90	84
27	183	116	116	45	166	105	105	63	149	94	94				
28	182	115	115	46	165	104	104	64	148	94	94				
29	181	115	115	47	164	104	104	65	147	93	93				

9.7 Program Simple Handle Instruction

1. The program will be exercised based on the default weight 70kg (150lbs). Once you change the value. (Range: 23~130kg/ 50~286lbs), program will be exercised according to the latest weight value.
2. The guiding texts will be shown on the screen to guide you for the next setting step by step.
3. Under any setting screen, you can press  key to cancel editing, to return to previous screen.
4. During your workout, setting values will count down until "0", by the time, program is finished.
5. Under start/ready status, you can press  key to enter into manual run.
6. After starting the program, treadmill automatically adjusts the speed and incline in accordance with the program.
7. The incline system of this treadmill conforms to the relevant safety regulations as below.
 - a) During workout, press  key, Systems will enter PAUSE condition, then main motor and incline motor stop immediately, press  can back to the motor status before PAUSE.
 - b) Once program finishes or the time hits maximum value (99:59), warning sound will come up, and then treadmill stops to "run end" status.
 - c) During start/ready status if incline is not at LEVEL 0, press  key for 2 sec or press  key to start treadmill, incline will automatically return to LEVEL 0.
8. When incline is returning to LEVEL 0, to unplug SAFETY KEY can stop the incline motor.
9. Under PAUSE mode for 4 minutes or PUASE status, program run end and press  for a long time, then you can end this fitness and back to the start/steady mode.

STANDBY

- Standby: After powered and start, the beeper will have a sound of beep and enter weight setting windows after 2 seconds.

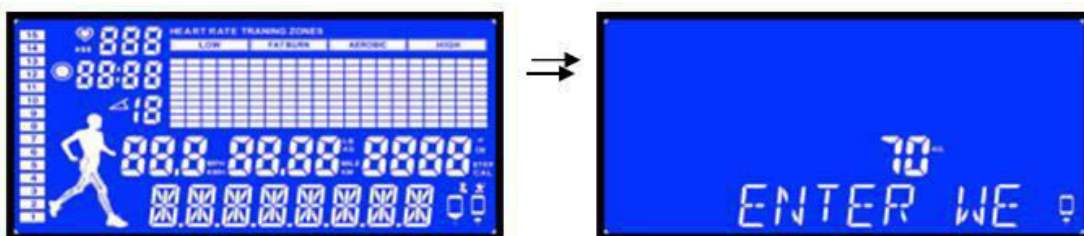

- Weight Setting:
 - a) Press SPEED+ or SPEED- for weight setting, preset value is 70KG(150 pound), range is 23~130 KG (50~286 pound)
 - b) Press ENTER to confirm the weight, screen will show "SELECT PROGRAM", press SPEED+ or SPEED- to select program controlling or press QUICK STERT for starting directly.

The purpose of weight setting is to let user know the calories expending and set the suitable formula for changing. The weight can be set for every restart. After run end to return the weight setting page or after SAFETY KEY being taken off.

- Dormancy: When there is no any operation for a long time, computer will enter dormancy. Systems will back to standby mode and close the screen light to save power. In dormancy condition, press any key can light the screen.

QUICK START MODE

- Start training:
 - a) In standby mode, press ENTER to confirm weight and press QUICK START to start the training directly. Screen words showing zone will show "READY GO" and after 3 seconds clockwise, the program start to working as speed of 0.8KPH(0.5MPH), the preset incline is 0°, fitness time is account from "0:00", the max value is 99:59.
 - b) During fitness:
 1. Press INCLINE QUICK KEY or press INCLINE↑ or INCLINE↓ to adjust the Incline angle.
 2. Press SPEED QUICK KEY or SPEED+ or SPEED- to adjust the current speed.

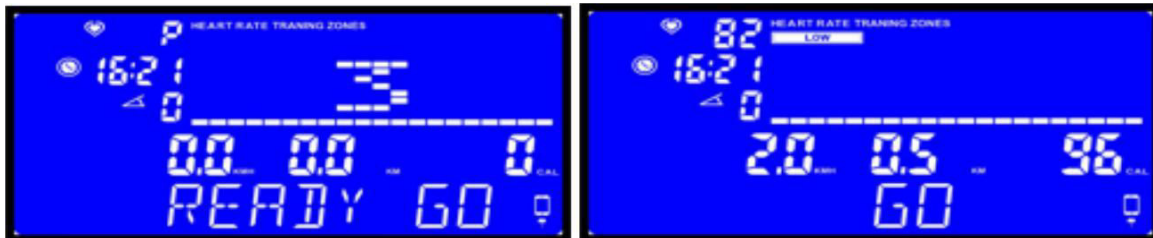

- Stop or finish training:
 - a) During fitness, press stop will enter PAUSE mode. In this time, the speed will slowly back to 0 and incline stop at the current angle.
 - b) When the fitness time is to 99:59 seconds or in program and finish the goal value (Time/Distance/Calories), in this time, the speed will slowly back to 0, incline stop at the current angle, screen will show "RUN END". Press STOP for 4 seconds or time is over 4 minutes, systems will back to standby mode.



PROGRAM MODE

- In standby mode, press ENTER to confirm weight, screen will show "SELECT PROGRAM".
- Press Mode or SPEED+ / SPEED- for program changing, the turn is as below:
MANUAL→ P1 →P2 →P3 →P4 →P5 →P6 →RANDOM→ USER→H.R.C.1-3→BODY FAT
- Press STOP can back to the upper selection list.

PROGRAM_Manual

1. Press ENTER to confirm select Manual and enter time setting:
Press SPEED+ or SPEED- to adjust the goal time, preset value is 0:00 and range is 0, 20:00~99:00, the unit is minute: second.
2. Press ENTER to confirm time and enter Distance setting:

Press SPEED+ or SPEED- to adjust goal distance, preset value is 0.00 and range is 0, 1.00-99.00, the unit is km (mile).

3. Press ENTER to confirm distance and enter calories setting:

Press SPEED+ or SPEED- to adjust the goal calories, preset value is 0 ,range is 0, 10-9990, the unit is calorie.

4. After finish above setting, press START to start the fitness, program will take the selected value as goal, when the goal value to be 0, the program run end

Note: Time, Distance, Calories can be circle setting, when set one of them, the other two will auto back to 0.

Note: Time, Distance, Calories can be circle setting, when set one of them, the other two will auto back to 0.

PROGRAM_P1 (9 hole) — 3.5km

1. Press ENTER to confirm select P1 and enter fitness intensity level setting:

Press SPEED+ or SPEED- to set Level, preset value is1, range is level 1 ~ level.

2. Press ENTER to confirm goal distance, screen will show "Ready Go" and after 3 seconds clockwise, then enter fitness mode.

PROGRAM_P2 (hill climb)

1. Press ENTER to confirm select P2 and enter intensity level setting:

Press SPEED+ or SPEED- to set Level, preset value is1,range is Level 1 ~ Level 10.

2. Press ENTER to confirm select Level and enter time setting:

Press SPEED+ or SPEED- to set time. Preset time is30:00, range is 0, 20:00-99:00, unit is minute: seconds.

3. Press ENTER to confirm goal time, screen will show "Ready Go" and after 3 seconds clockwise, then enter fitness mode.

PROGRAM_P3-P6: Way of setting as P2

Note: P1~P6 program refers to attachment.

PROGRAM_RANDOM (speed program that appeared by chance)

1. Press ENTER to confirm select Random and enter goal time setting:

Press SPEED+ or SPEED- to enter time setting, preset value is 0:00, range is 0 , 20:00-99:00,unit is minute: seconds.

2. Press ENTER to confirm setting time and enter distance setting:

Press SPEED+ or SPEED- to set distance, preset value is 0.00, range is 0 , 1.00-99.00, unit is km (mile).

3. Press ENTER to confirm set distance and enter Calories setting:

Press SPEED+ or SPEED- to adjust goal calories, preset value is 0 , range is 0, 10-9990,unit is calorie.

4. After finish setting, press START to start fitness.

Note: Time, Distance, Calories can be circle setting, when set one of them, the other two will auto back to 0.

PROGRAM_USER (can be set by yourself: Speed & Incline)

1. Press ENTER to confirm USER and enter to select U1 ~U4, systems total can store 4sets program

a) Press SPEED+ or SPEED- to selectU1, U2, U3, U4.

- b) Press ENTER for 3 seconds and enter self-setting, press SPEED+ or SPEED- to adjust Speed drawing and press INCLINE+ or INCLINE- to adjust Incline drawing, press ENTER to select next Profile zone adjustment (Total 20 stage). After finished the management, press ENTER for 3 seconds then can save the managed value.
2. Press ENTER to select U1 and enter time setting:

Press SPEED+ or SPEED- to set time. Preset time is 0:00, range is 0, 20:00-99:00, unit is minute: second.
3. Press ENTER to confirm time and enter distance setting:

Press SPEED+ or SPEED- to set distance, preset value is 0.00, range is 0, 1.00-99.00, unit is km (mile).
4. Press ENTER to confirm distance and enter Calories setting:

Press SPEED+ or SPEED- to set calorie, preset value is 0, range is 0, 10-9990, unit is calorie.
5. After finish setting, press start to start fitness.

Note: Time, Distance, Calories can be circle setting, when set one of them, the other two will auto back to 0.

H.R.C 1-3

This program's training goal is HRC, when the center value up to the preset value you set, the incline and speed will steady and HRC in a range to reach the training goal.

This HRC program total 3 kinds, as 60%, 75% and THR (self-setting).

Press ENTER to confirm select H.R.C 1-3 and enter to select 60%, 75%, Target Heart Rate (below as THR).

Press SPEED+ or SPEED- to select 60%, 75%, THR.

Note: In mode of HRC, only can receive wireless pulse signal (advise to match a wireless pulse chest belt). If systems do not receive the pulse signal for 45 seconds, systems will auto stop and show "NO PULSE" words, press STOP or over 4 minutes and systems will back to standby mode.

When execute program, speed will down or up by actual pulse per 10 seconds. If the actual pulse lower than goal pulse, the speed will increase 0.1 KPH (MPH), If actual pulse upper than goal pulse, the speed will decrease 0.1 KPH (MPH), and if increase speed for 10 times, the incline will increase 1 level. If decrease speed for 10 times, incline decrease 1 level. Speed can reach to the max value Speed can reach to the lower value 0.8KPH (0.5 MPH) the max incline level is 15

1. 60%,75%

- a) Press ENTER to confirm select 60% and enter time setting:

Press SPEED+ or SPEED- to set time, preset value is 0:00, range is 20:00-99:00, unit is minute: second.
- b) Press ENTER to confirm time and enter age setting:

Press SPEED+ or SPEED- to set age, preset value is 30, range is 13-80.
- c) Press ENTER to confirm age, bpm window will show ages, then account with the formula to HRC goal value
- d) Press ENTER to confirm goal pulse value, screen will show "Ready Go" and clockwise for 3 seconds, then enter fitness mode.
- e) After program start, actual pulse will show at BPM window and THR window will show goal pulse.

2. THR (Target Heart Rate)

- a) Press ENTER to confirm select THR and enter time setting:

Press SPEED+ or SPEED- to set time, preset value is 0:00, range is 20:00-99:00, unit is minute: second.

- b) Press ENTER to confirm time and enter pulse value setting:
Press SPEED+ or SPEED- to set pulse value, preset value is 72, add 1 per time.
- c) Press ENTER to confirm goal pulse value, screen will show "Ready Go" and clockwise 3 seconds to enter fitness mode.

BODY FAT MODE

- Press ENTER to select "BODY FAT" and program will ask for below information:
- a) Age: Preset value is 30,range:13~80,Step is 1,press speed+/- for adjustment and when you selected the right value, press ENTER to next value setting.
- b) Height: preset value is 170 cm (66 inch),range:120~200 cm (47-78 inch), Step is 1 cm (inch), press speed+/- for adjustment and when you selected the right value, press ENTER to next value setting.
- c) Sex: preset is male. Press speed+/- change from male(M) to female(F) or female(F) to male(M). When you selected the right one, press ENTER to next program setting.
- d) Weight: preset value is 70 kg(150LB),range:23~130kg(50~286LB),Step is 1 kg, press speed+/- for adjustment and when you selected the right value, press ENTER for storing.
- Please hold the pulse detector for 15seconds by your two hands and windows will show body fat value after 15 seconds(result referring list as below).
- After systems showing the value, press STOP or after 1munite, it will turn back to steady/start windows.

sex	Under		Normal		Over		Obesity	
M.(male)	0.0~4.9	5.0~9.9	10.0~14.9	15.0~19.9	20.0~24.9	25.0~29.9	30.0~34.9	Over 35.0
F.(female)	0.0~14.9	15.0~19.9	20.0~24.9	25.0~29.9	30.0~34.9	35.0~39.9	40.0~44.9	Over 45.0

PROGRAM DRAWING

P1 - P6 drawing total is 30levels, 1minute per level and showing by turns

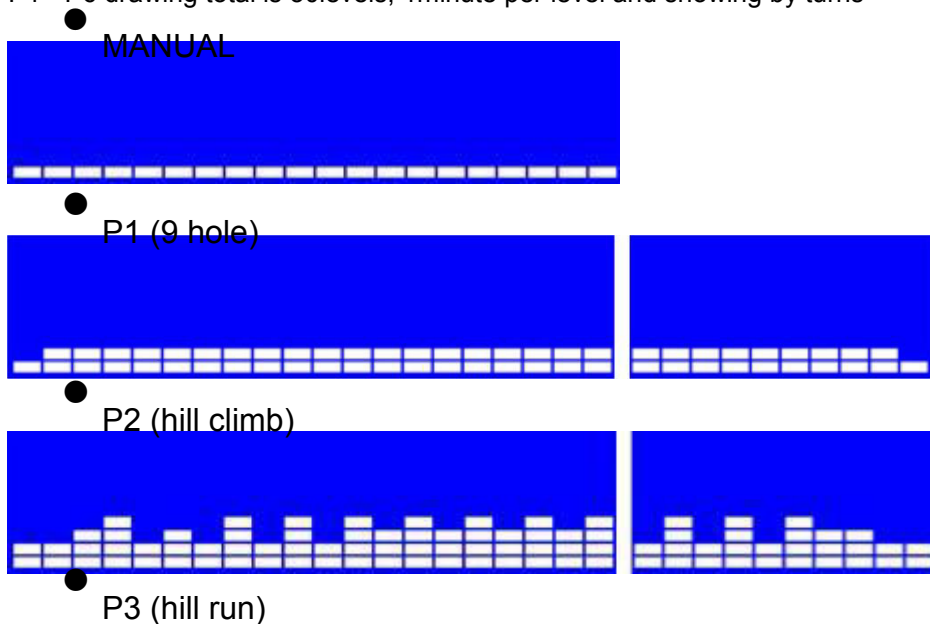

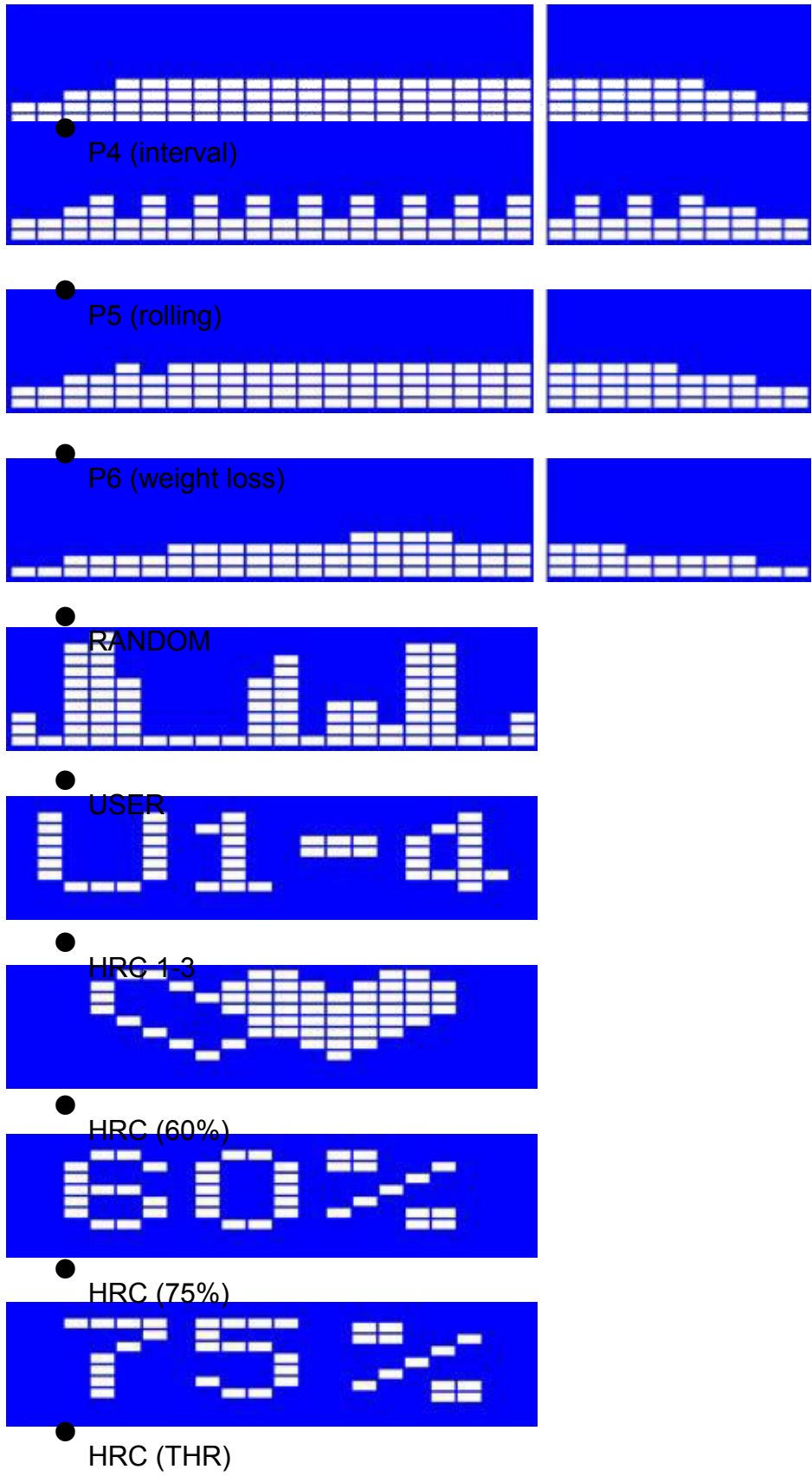

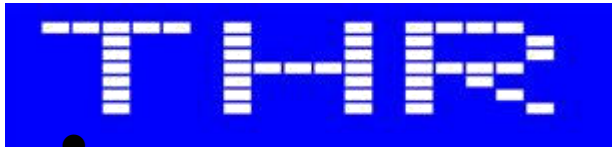

BODY FAT

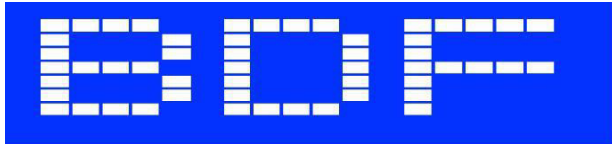

- **Metric/inch system switch mode:**

Under weight reset pages, press enter for 10 seconds will enter metric/inch systems switch mode, if it is inch system, LCD windows will show "ML". If it is metric systems, windows will show "KM", press speed +/- and you can switch metric/inch systems mode, then you can press enter for confirming. If you have switched the mode, program will do the preset working.

Error WARNING INFORMATION

When treadmill motor can not work or signal can not delivery, machine will auto stop and show below information for user checking.

- E1: Can not read the speed value, maybe motor is in trouble or signal can not be delivered.
- E6: Incline data is wrong, incline motor damaged or signal can not delivery.
- E7: Incline AD over the normal range, incline motor damaged or wrong setting.

9.8 APP (iOS&Andriod) INSTALLATION GUIDANCE



- **Needed appliances**

Specific computer console of specific BTM- BT module set (left picture), or specific 5V – USB connected exterior BT module device (right picture)



Smart phone or I-pad with BT version 3.0 or better.

For iOS Device(iPad)

1. APP software download

Connect iPad to App(iTunes) Store and search for “Kinomap Fitness”, then read the APP instruction and download APP. After installation, the main page will show “Kinomap Fitness” icon.

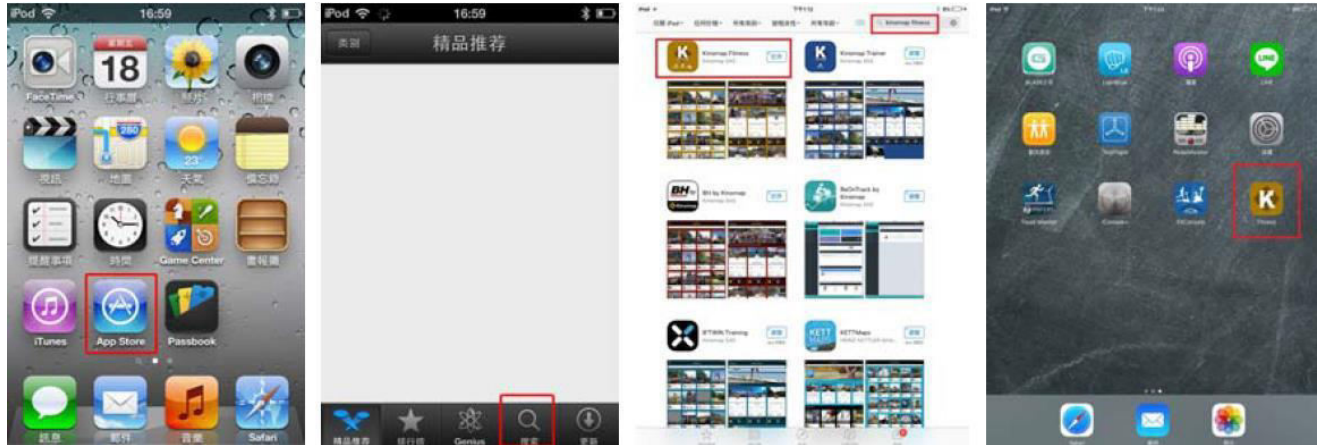

Account registration:

“Kinomap Fitness” is free program, the user should use the official website to create ID account, password and basic information. After registration, the exercise data will be stored to the APP cloud data bank.

Sign in to Kinomap Support

Email

Password

Stay signed in

Sign in

Your credentials will be sent over a secure connection

Cancel

[Forgot my password](#)

New to Kinomap Support? [Sign up](#)

Have you emailed us? [Get a password](#)

If you've communicated with our support staff through email previously, you're already registered. You probably don't have a password yet, though.

More details about registration are on the website below:

<http://support.kinomap.com/hc/en-us/sections/200654535-Kinomap-Fitness>

2. BT device matching and APP working :

STEP.1

Please place iPad on area in front of LCD screen.

STEP.2

Enter iPad Settings program.



STEP.3

Open BT, iPad will detect all BT devices within the scope. Please find the treadmill BT device name, and click it for matching.

- When many BT devices are detected and you can't recognize the corresponding name, please contact the dealer.

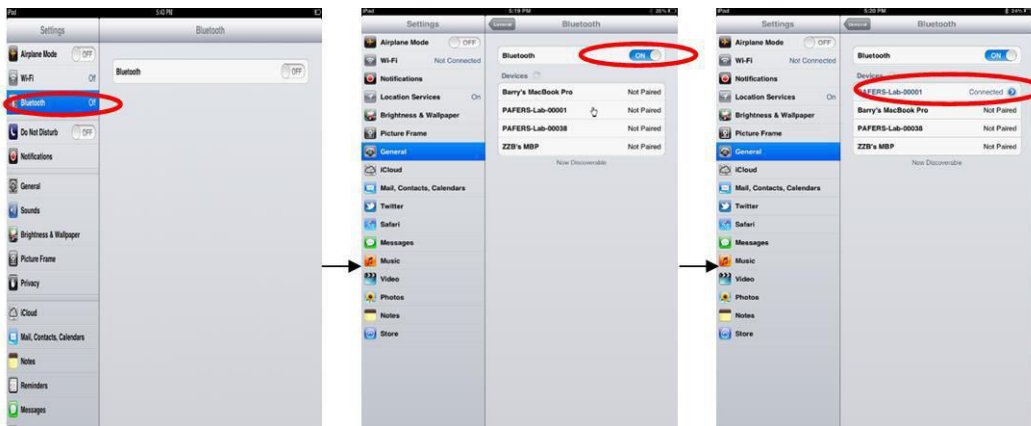

STEP.4

Please wait for a few seconds until the status of the device change to "connected", then check if there

is the figure  showing on top right hand corner of iPad (White mark means BT is matched successfully; grey mark means BT is open but not matched).

STEP.5

After BT is connected successfully for 10 seconds, LCD display will show white background and the

figure on bottom right hand corner will change from  to , it means the computer also has connected with iPad successfully.

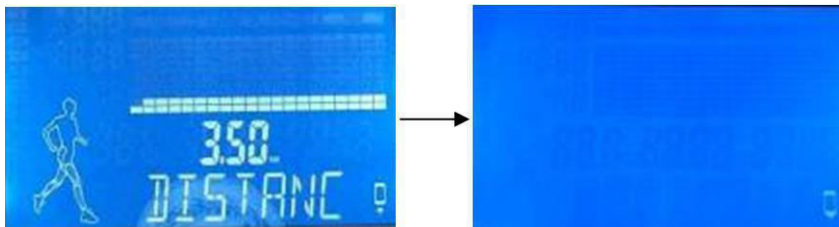

STEP.6

Press "HOME" button  on iPad and the screen will go to iPad desktop, and then download the Kinomap Fitness APP.

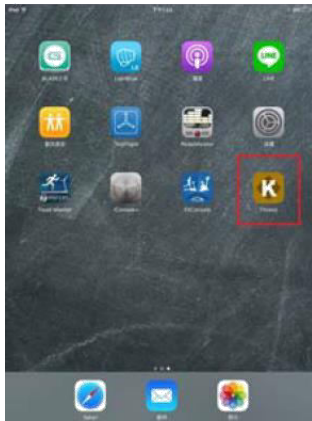

STEP.7

After entering the Kinomap Fitness APP, press the upper left “function chart” and then press the lower left “camera appliance”.

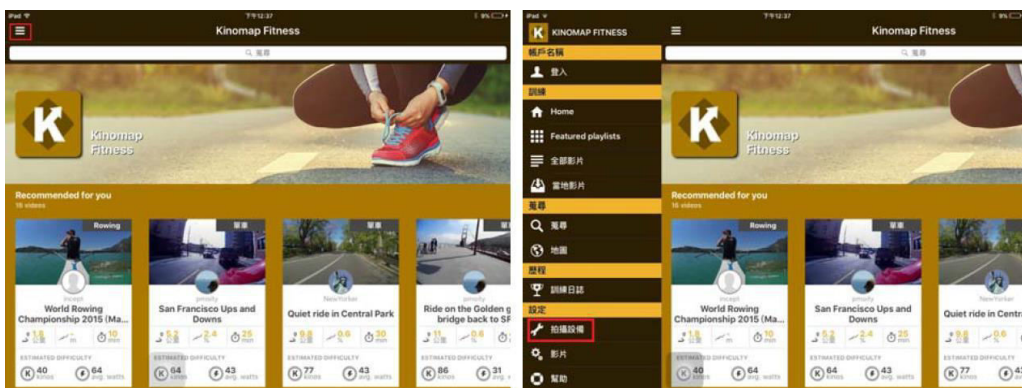

STEP.8

After entering the program set, press “+” in the upper right corner and press “add new appliance”

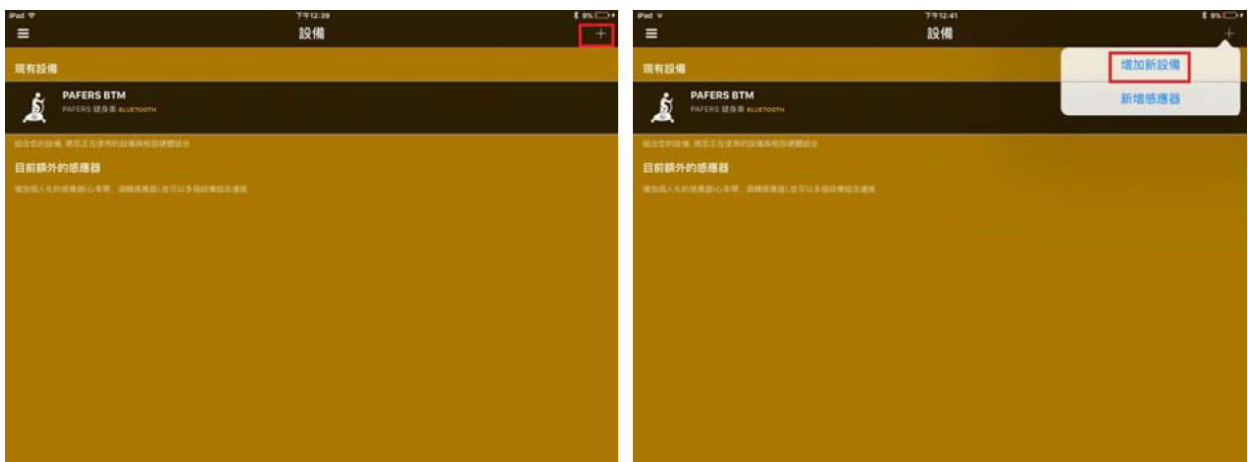

STEP.9

In the equipment page, choose the machine. Choose “Treadmill”, “Exercise bike” etc. and then choose “PAFERS” in the brand page.

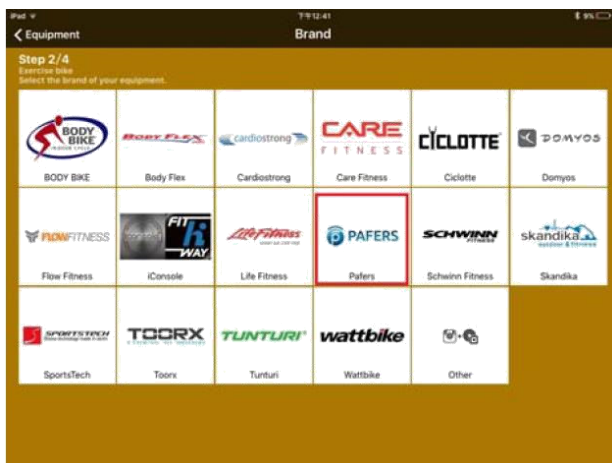
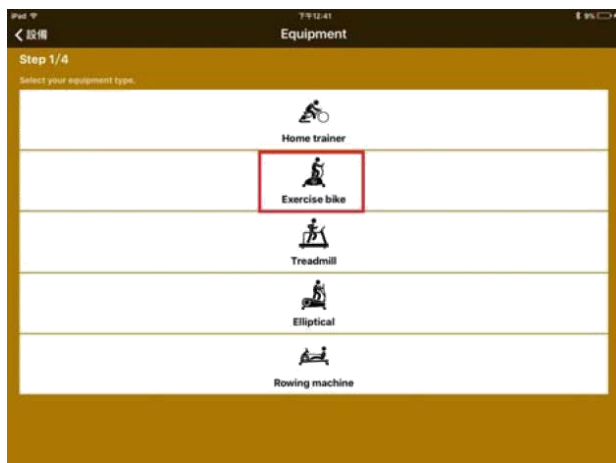

STEP.10

After that the page will show “Model” page, and below will be shown chosen machine type, such as “+pafers exercise bike”, click the program and choose “BLUETOOTH” as shown in the picture below.

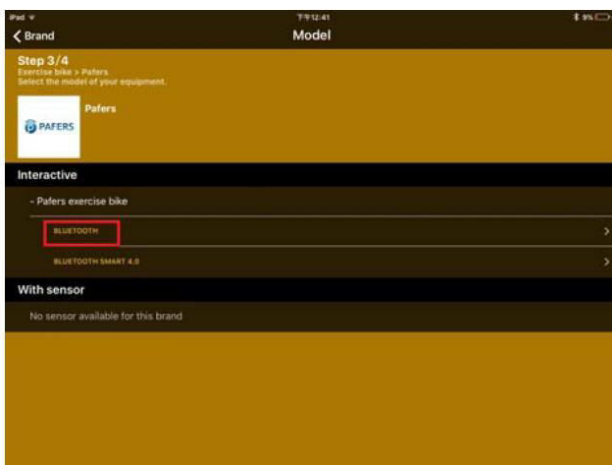
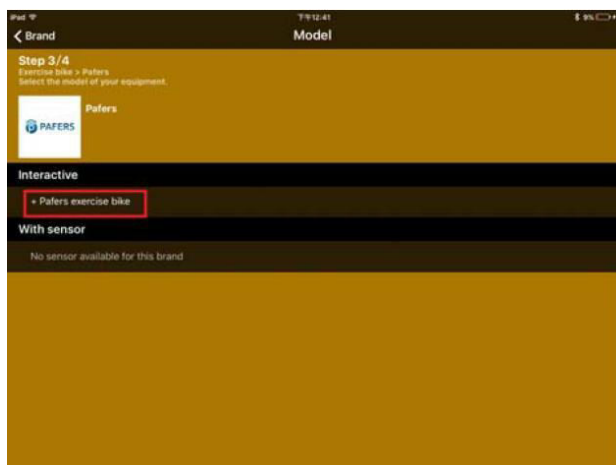

STEP.11

Press “PAFFERS BTM” and then press “Done” in the upper right corner.

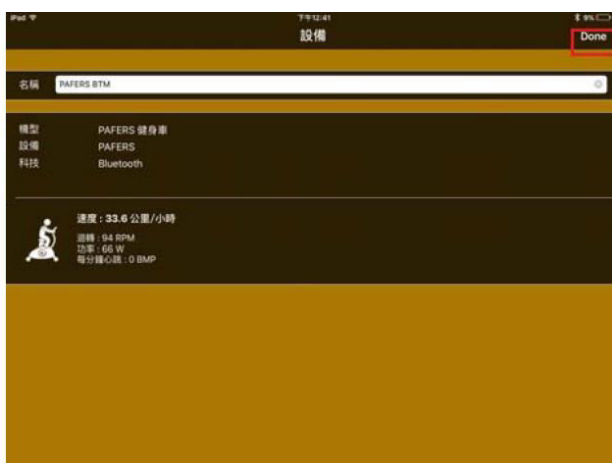
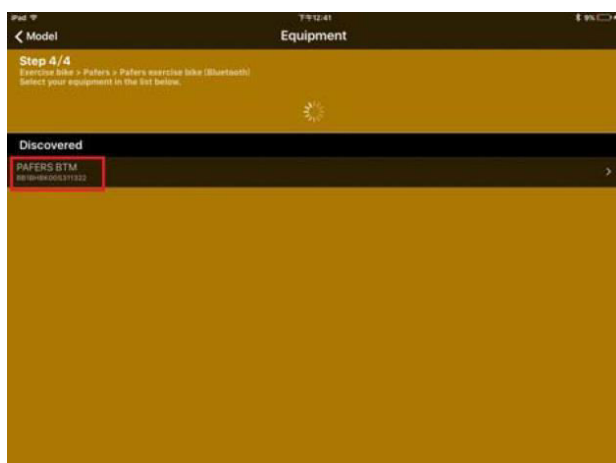

STEP.12

Click the “HOME” on the left menu to turn back to the main page and choose “Exercise mode” to start the exercise.

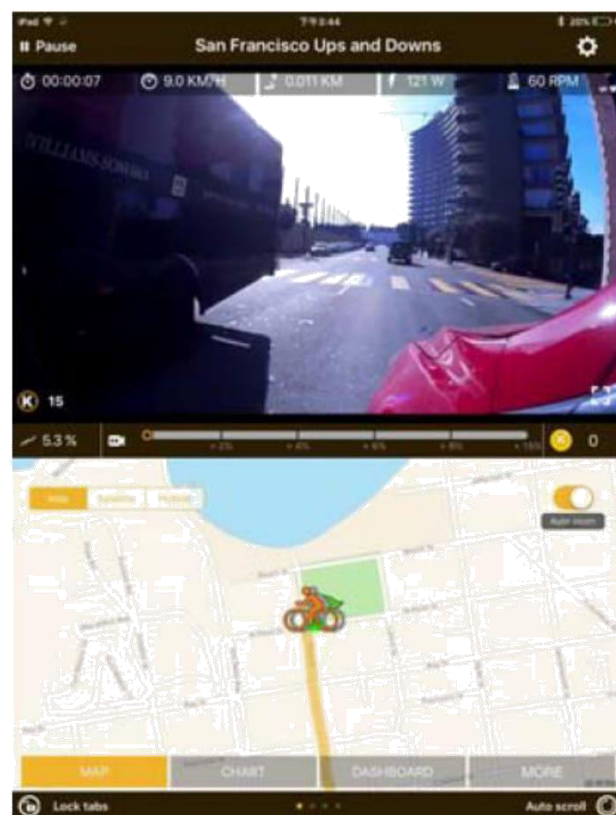
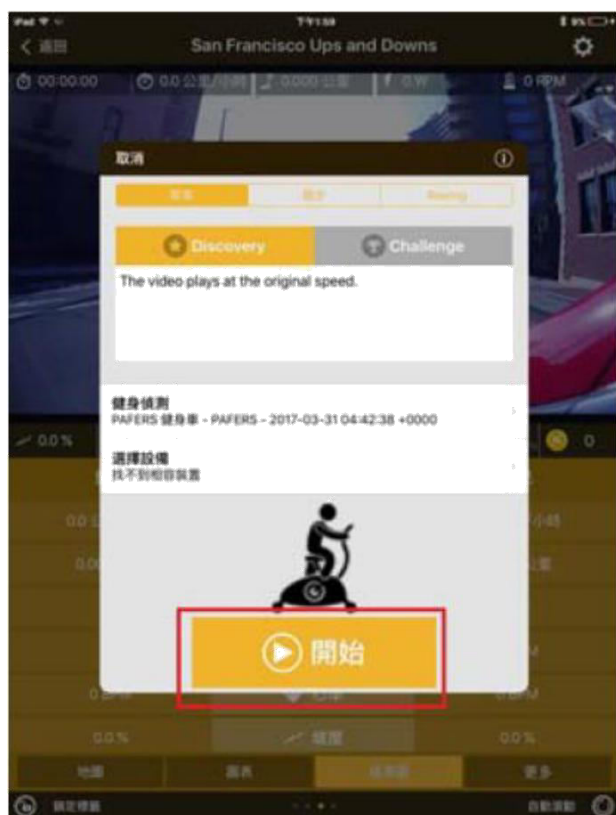
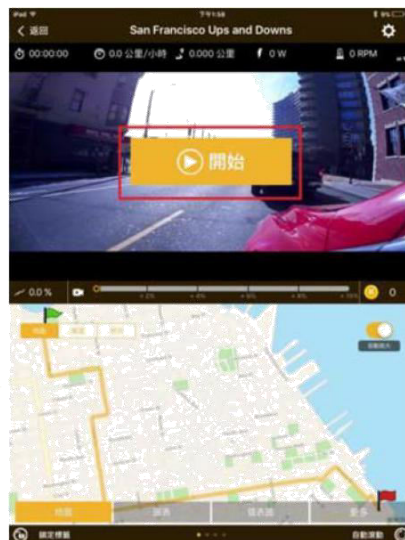
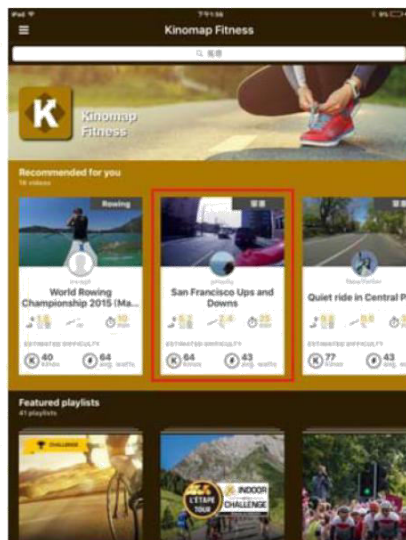

More information in link below:

<http://support.kinomap.com/hc/en-us/sections/200654535-Kinomap-Fitness>

NOTE:

Every time after using the APP, press “HOME” button on “iPad” twice, close recently used APP in the background (as figures below). Then go back to iPad Settings page to close BT function. After about 10 seconds, the computer will have a beep sound and it will return to regular LCD operation display.

For Andriod Device

1. APP software download:

Connect Andriod tablet to Play Store, search for pafers, then read APP instruction, download APP with treadmill function into your tablet, for example "Run On Earth". Other APPs not designed for treadmill can't connect with this computer.

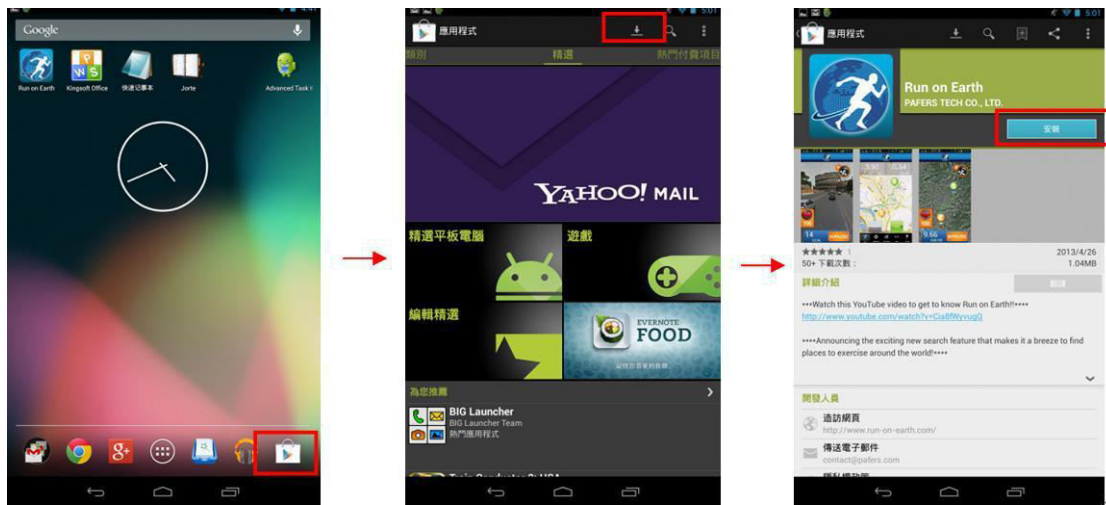

2. BT device matching and APP working:

STEP.1

Please place Andriod tablet on area in front of LCD screen.

STEP.2

Enter tablet Settings program and open BT.

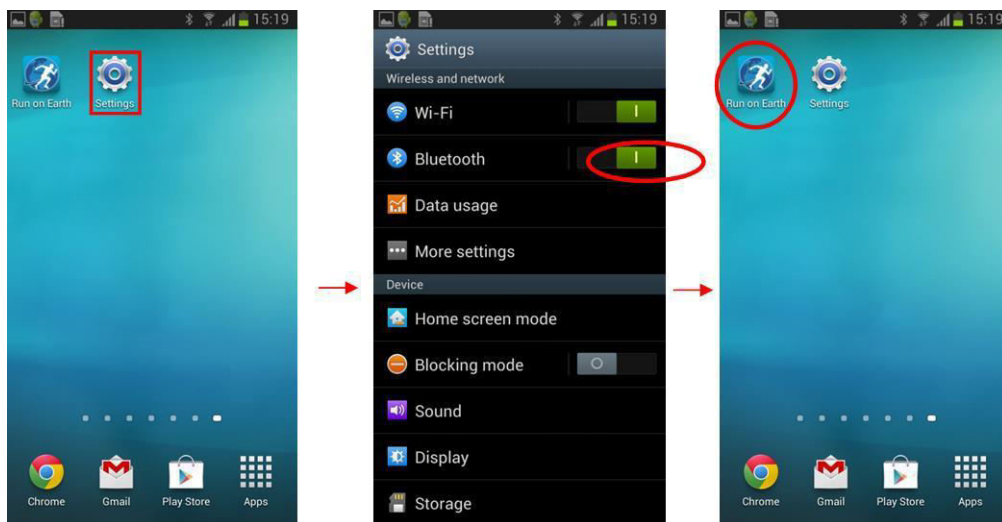

STEP.3

Press "HOME" page button to go to desktop, and open the APP downloaded from Play Store.

STEP.4

After entering APP page, treadmill will detect APP, then connecting option page will jump out, press Connect and Andriod tablet will detect all BT devices within the scope. Please find the treadmill BT device name and click it for matching.

- When many BT devices are detected and you can't recognize the corresponding name, please contact the dealer.

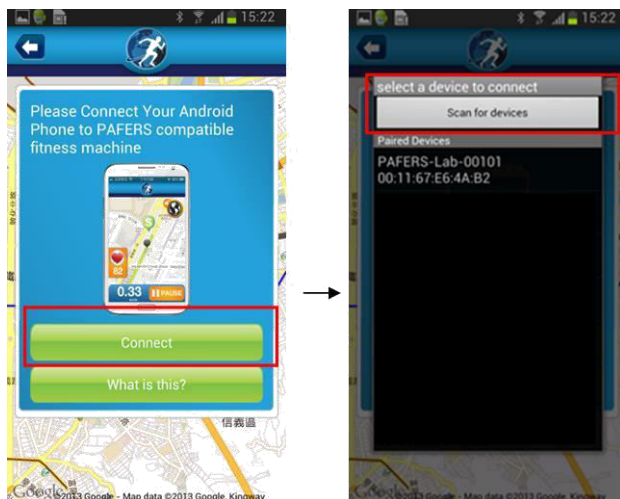



STEP.5

Please wait for a few seconds until the status of the device change to "connected", then check if there is the figure  showing on top right hand corner of tablet (White mark means BT is matched successfully; grey mark means BT is open but not matched).

STEP.6

After BT is connected successfully, the App icon on screen will be unlocked. LCD display will show

white background and the figure on bottom right hand corner will change from  to , it means the computer has connected with tablet successfully, and you can start using every mode on APP interface to control the treadmill.

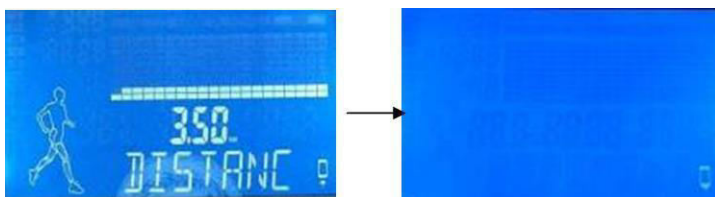

STEP.7

Every time after using the APP, please close used APP in the background. Then please go back to Andriod tablet Setting page to close BT function. After about 10 seconds, computer will have a beep sound and it will return to regular LCD operation display.

REMARKS

- APP function is based on the connection with treadmill via BT, so please confirm the treadmill is equipped with BT set.
- After matching successfully, please start treadmill APP within 2 minutes. If App is not started within 2minutes or the distance between tablet and treadmill is over 2meters, the connection will be interrupted automatically and please reset above steps.
- This BT device also supports others app than Kinomap such as Fitconsole app from Pafers. For more details please visit the website below:
<https://itunes.apple.com/tw/app/fitconsole/id936724477?l=zh&mt=8>
<http://www.pafers.com/en/apps/fitconsole> - consult with salesman
- APP will not change the unit Metric/English automatically, when the unit between APP and console is different, please switch the unit in APP.
- The software will be updated or new APP will be launched on an unfixed schedule.

- APP contains the functions below, we suggest users to open 3G network or Wi-Fi network in order to enjoy the complete functions.
- a) FITNESS MANAGEMENT :Register your personal account in APP and sign in, you can record or review your fitness data for every exercise session.
- b) Some APP requires connection to Google Map for position, and the page can be used as operation display interface after position.

Circumstances below may cause APP connection interruption or crash:

When using APP, use background applications synchronously, such as music listening, picture scanning and so on. Please try to reduce the number of times back and forth or avoid opening too many applications. Sometimes the connection will be interrupted due to resource allocation and self protection of the tablet.

- If the connection is interrupted, treadmill will start protection function, making a continuous warning beep sound, and then automatically shut down the speed of treadmill to avoid user's safety problem.

If iOS Device APP can't use normally, please refer to the following steps to recover the connection:

STEP.1

Quickly double press "HOME" button on iPad and delete all APPs in the temporary memory (including Pafers APP).

STEP.2

Enter iPad Settings program, press the "→" on the right of BT device name and choose "Yes" to forget this BT device.

STEP.3

Close BT function and turn off treadmill.

STEP.4

Turn on treadmill after 10 seconds.

STEP.5

Enter iPad Settings program, open BT function, search the treadmill BT device name and re-matching.

STEP.6

After matching successfully, please go back to desktop and re-start Pafers APP.

- If the problem is still not solved, please check if the BT device matched with iPad belongs to this treadmill. If it's positive, please turn off the iPad temporarily, the iPad might crash or encounter other wireless interference.

If Android Device APP can't use normally, please refer to the following steps to recover the connection:

STEP.1

Search, download and install "Advanced Task Killer" in Google play store. Open the "Advanced Task Killer", select all APPs (including Pafers APP), and then press „Kill selected App”.

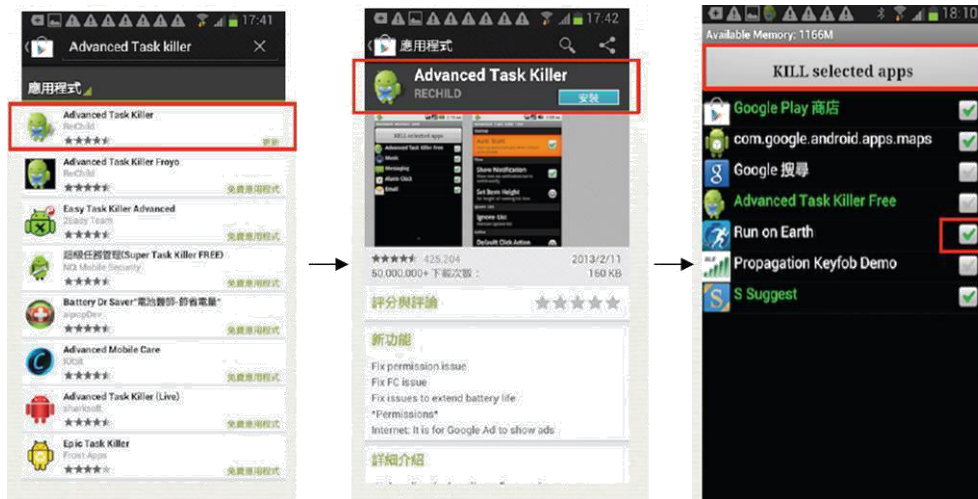

STEP.2

Enter Android tablet Settings program, press "cancel matching".



STEP.3

Close BT function and turn off treadmill.

STEP.4

Turn on treadmill after 10 seconds.

STEP.5

Enter Android tablet Settings program, open BT function, search the treadmill BT device name and re-matching.

STEP.6

After matching successfully, please go back to desktop and re-start Pafers APP.

- If the problem is still not solved, please check if the BT device matched with Andriod tablet belongs to this treadmill. If it's positive, please turn off your Andriod tablet temporarily, the Android tablet might crash or encounter other wireless interference.

APP SUPPORTIVE DEVICES (below-listed for example, please refer to the declaration on APP downloading page as validation)

- Apple Device: iOS 8.0 or newer
- Android Device: 5.0 or newer



- For other iOS or Android devices not included in the declared list, the APP can still be installed and used. Due to different screen size, picture ratio and resolution, figures may be displayed imperfectly and calibration is required. The models above-listed have been calibrated, any update will be declared on pafers website.
- Advice update IOS to 6.0 version or above, Android to 4.0 or above, allow users to have the best experience.

10. PARTS LIST

NO	item no.	Description	q'ty needed/set
1	HTF230E-D1	computer console	1
2	SDA8-30I	truss hex screw M8xP1.25x30	2
3	SOC8	nylon nut M8xP1.25	12
4-2	RD-20-0004	film keyboard 20 keys	1
4A	BAE0300-300-10	rubber pad 30mmx30mmx1.0t single side tape black	1
5	JTFD002	computer shelf with handrail assembly	1
6-1	P-3182	hand grip pulse plastic base	2
6-2	NO-4994	hand grip pulse sensor plate	4
6-3	RBA-039	handrail switch sticker speed	1
7-3	RBA-040	handrail switch sticker incline	1
8	XL-1239	handrial switch+lower hand grip wire	2
	XEK-282	Hand Pulse keyboard plate	2
9	SAK3-8	round head philips self-tapping screw (flat end) ø3x8	22
10E	XRA-179-003	computer (7"LCD display with board) T1L	1
11	RCA-001	computer decal left for treadmill	1
12	RCA-002	computer decal right for treadmill	1
13	RCA	computer decal for treadmill	1
14	P-3185	handrail upper cover	1
15	P-3186	handrail lower cover	1
16A	XEK-277	transferring board (T1 and T1L)	1
20	HTFC002L	handrail tube assembly (L)-JTFB004L	1
		PU handrail (L) P-3179L	1
		handrail tube shooting pad(L) P-3181L	1
20-1	P-3180L	handrail tube sleeve cover L	1
20-2	SCI4-10	truss philips self-tapping screwΦ4x10	10
Note:		PU handrail set must be bought with (20-1)*1 (9)*1(20-2)*5	
21	HTFC002R	handrail tube assembly (R)-JTFB004R	1
		PU handrail (R)P-3179R	1
		handrail tube shooting pad(R) P-3181R	1
21-1	P-3180R	handrail tube sleeve cover R	1
Note:		PU handrail set(21) must be bought with (21-1)*1 (9)*1(20-2)*5	
23	SPA050-100-20	flat washer ψ5Xψ10X2.0t	2
24	SAE5-10	round head philips screw(cuttend end) M5xP0.8x10	2

25	SHA6-12N	counter sink philips screw M6XP1.0X12(ni)	3
27	SCI4-16	truss philips self-tapping screw Φ 4x16	10
28	SDA8-15I	truss hex screw M8xP1.25x15	8
31	XEK-028-260	hand grip pulse board	1
32	SCI5-15	truss philips self-tapping screw Φ 5x15	7
35	XL-836B	lower control wire	1
36	XL-1258	transferring board connecting wire upper	1
37	XL-1241B	transferring board connecting wire lower	1
38	XL-1250	upper control wire	1
39	SCE5-10	truss philips self-tapping(cuttend end) M5xP0.8x10	10
40	XL-1237	handrail switch +upper hand grip wire	2
41	XL-1242	film keyboard transferring wire	1
43	P-3184	lower computer	1
44	JTFA047	computer shelf assembly	1
45	P-2214	safety clip	1
46	DEC-20-1100	nylon rope Φ 2.0x1100mm	1
47	PM-001	clip	1
48	XEM-016	safety switch set 650mm	1
49	SAI3-8	round head philips self-tapping screw Φ 3x8	4
50	JTCA063	upright tube assembly L	1
51	JTCB057	upright tube assembly R	1
52	SK-298A	truss hex screw	8
54	P-2588	motor cover	1
55	SCE5-15	truss philips screw(cuttend end) M5xP0.8x15	23
56	BAA1000-120-50	foam sticker 100mmx12mmx5t single side tape	2
57	XM-121	incline motor	1
58	SK-439	cks hex screw M10xP1.5x40	1
59	SOC10	nylon nut M10xP1.5	3
60	XM-230B	motor	1
61	SGA10-25I	cks hex screw M10xP1.5x25	4
62	SPA100-200-30	flat washer ϕ 10x ϕ 20x3t	4
63	SPB10	spring washer M10	6
64	CA-240J8	drive belt 240J10	1
65	SGA8-80I	cks hex screw M8xP1.25x80	1
66	SOA8	hex screw nut M8xP1.25	1
67	PEC-UC-1	wire clip fixing knob	2
68	SAA5-10GZ	round head philips screw M5xP0.8x10	5
70	SOC10-8T	nylon nut M10xP1.5x8t	1

71	XEH-002-001	power wire socket	1
72	XEA-A001	power switch	1
73	XLZ-TM	power wire	1
74	P-1825	power wire socket	1
75	BAC-009	<small>foam double side tape #21x1.0</small>	4
	ZAV-001	<small>transparent sucker #18x#22</small>	4
76	XEG-10-001	circuit breaker	1
77	NT-1636	power wire collector	1
78	XEM-002	sensor	1
79	SCE4-10	truss philips screw (cutted end) M4xP0.7x10	4
80	P-2231	sensor fixing base	1
81	NO-2399	sensor fixing plate	1
82	P-1301	fixing buffer pad	6
83	MB-011	running board	1
Note:		running board(83) must be bought with grounding sticker(154)*2 (155)*3	
84	SCI4-12	truss philips self-tapping screw $\varnothing 4 \times 12$	1
85	BJ-22-080B	belt 2.2mmx80mm black	1
86	SIA8-35I	counter sink hex screw M8xP1.25x35	6
87	SIA8-40I	counter sink hex screw M8xP1.25x40	4
88	NAL001E1500	AL pedal	2
Note:		AL pedal (88) must be bought with foam sticker (89A)	
89A	BAA15000-200-15	foam sticker 1500mmx20mmx1.5t single side tape black	2
90	NO-3805	AL pedal fixing plate	8
91	XEJ-T35x23	iron core ring	1
92	P-1096L	rear end cap L	1
93	P-1096R	rear end cap R	1
95	CB00029B	running belt	1
96	NRL-005	front roller	1
97	SGA10-100I	cks hex screw M10xP1.5x100	1
98	SPA100-200-10	flat washer $\varnothing 10 \times \varnothing 20 \times 1t$	1
99	SPD10	inner toothed washer M10	1
100	SOA10	hex screw nut M10xP1.5	1
101	XLT044	extension wire(kelly) 14AWGx450x2R(one R end is inner toothed,the other R end is toothless)	1
102	NRL-005A	rear roller	1
103	SGA10-80I	cks hex screw M10xP1.5x80	2
104	NO-4059	dustproof iron plate	1

105	SPB5	spring washer M5	4
106	SCE5-12	truss philips screw (cutted end) M5xP0.8x12	6
107	P-1032	rubber foot pad	2
108	SCE6-10	truss philips screw (cutted end) M6xP1.0x10	4
109	JTBC010	incline base assembly	1
110	NT-1000	incline base fixing base	2
111	SGA8-25I	cks hex screw M8xP1.25x25	4
112	P-1037	plastic sleeve cover	2
113	PB-00-003	wheel $\varnothing 60 \times \varnothing 10 \times 30$ black	2
114	SGC10-60-30I	cks hex screw M10xP1.5x60 thread length 30mm	2
115	NT-1379	incline base extending \square iron plate pin	2
116	SQC100-20	R pin	2
117	P-1155	foot pad	2
118	SPA060-160-10	washer $\varnothing 6 \times \varnothing 16 \times 1t$	2
119	SMM4-16	washer drill philips self-tapping screw $\varnothing 4 \times 16$	2
120	JTAA042	frame assembly	1
121	XLT002	extension wire(white) 14AWGx90x2t	1
122	XLT001	extension wire(black) 14AWGx90x2t	2
123	XLT074	extension wire(kelly) 14AWGx300x1T1R (R end is inner toothed+T end is mother end)	1
124	XLT027	extension wire(white) 14AWGx260x2t	2
125	XLT029	extension wire(black) 14AWGx260x2t	1
126	XLT047	extension wire(kelly) 14AWGx500x2R(R end is inner toothed)	1
128	PEC-HC-25	KSS wire clip fixing base	1
129	BJ-36-163B	belt 3.6mmx163mm black	2
130	BE-1500	Missing in scheme	1
132	BJ-48-330B	belt 4.8x330mm black	3
135	SSB8-200	T shaped wrench	1
136	SSA6-80-80M	hex wrench 6mmx80mmx80mm	1
137	SSH5-70-70M	L hex wrench + philips screwdriver 5mmx70mmx70mm	1
138	BD-001-100	bottled Silicon DC-1000	1
140	XL-1251	middle control wire	1
142	NT-771	water bottle holder	1
143	SEA8-115-25	hexagon screw M8xP1.25x115 thread length 25mm	8
144	SPA080-200-20	washer $\varnothing 8 \times \varnothing 20 \times 2t$	8
145	SPB8	spring washer M8	14
146	P-2589L	motor side cover L	1
147	P-2589R	motor side cover R	1

154	RBA-016	grounding sticker (Al foil with single side tape)20x1390L	2
155	RBA-014	grounding sticker (Al foil with single side tape)20x670L	3
156	XHA-T34	Chest Belt Pulse Emitter POLAR T34	1
157	XEN-008	inductance	1
158	SAE5-8	round head philips screw(cuttend end) M5xP0.8x8	2
159	XEB-009	filter	1
160	P-1853	adjustment screw cover(black)	1
161	SPA030-080-05	washer $\varnothing 3 \times \varnothing 8 \times 0.5t$	1
163	XRB-023-017B	transducer (2.0Hp,220V) RM5LD-2002-12V 1.5A	1
165	P-1685	isolution pad upper	4
166	P-1686	isolution pad lower	4
155	RBA-014	grounding sticker (Al foil with single side tape)20x670L	3
156	XHA-T34	Chest Belt Pulse Emitter POLAR T34	1
157	XEN-008	inductance	1
158	SAE5-8	round head philips screw(cuttend end) M5xP0.8x8	2
159	XEB-009	filter	1
160	P-1853	adjustment screw cover(black)	1
161	SPA030-080-05	washer $\varnothing 3 \times \varnothing 8 \times 0.5t$	1
163	XRB-023-017B	transducer (2.0Hp,220V) RM5LD-2002-12V 1.5A	1
165	P-1685	isolution pad upper	4
166	P-1686	isolution pad lower	4
155	RBA-014	grounding sticker (Al foil with single side tape)20x670L	3
156	XHA-T34	Chest Belt Pulse Emitter POLAR T34	1
157	XEN-008	inductance	1
158	SAE5-8	round head philips screw(cuttend end) M5xP0.8x8	2
159	XEB-009	filter	1
160	P-1853	adjustment screw cover(black)	1
161	SPA030-080-05	washer $\varnothing 3 \times \varnothing 8 \times 0.5t$	1
163	XRB-023-017B	transducer (2.0Hp,220V) RM5LD-2002-12V 1.5A	1
165	P-1685	isolution pad upper	4
166	P-1686	isolution pad lower	4

11. EXPLODED VIEW

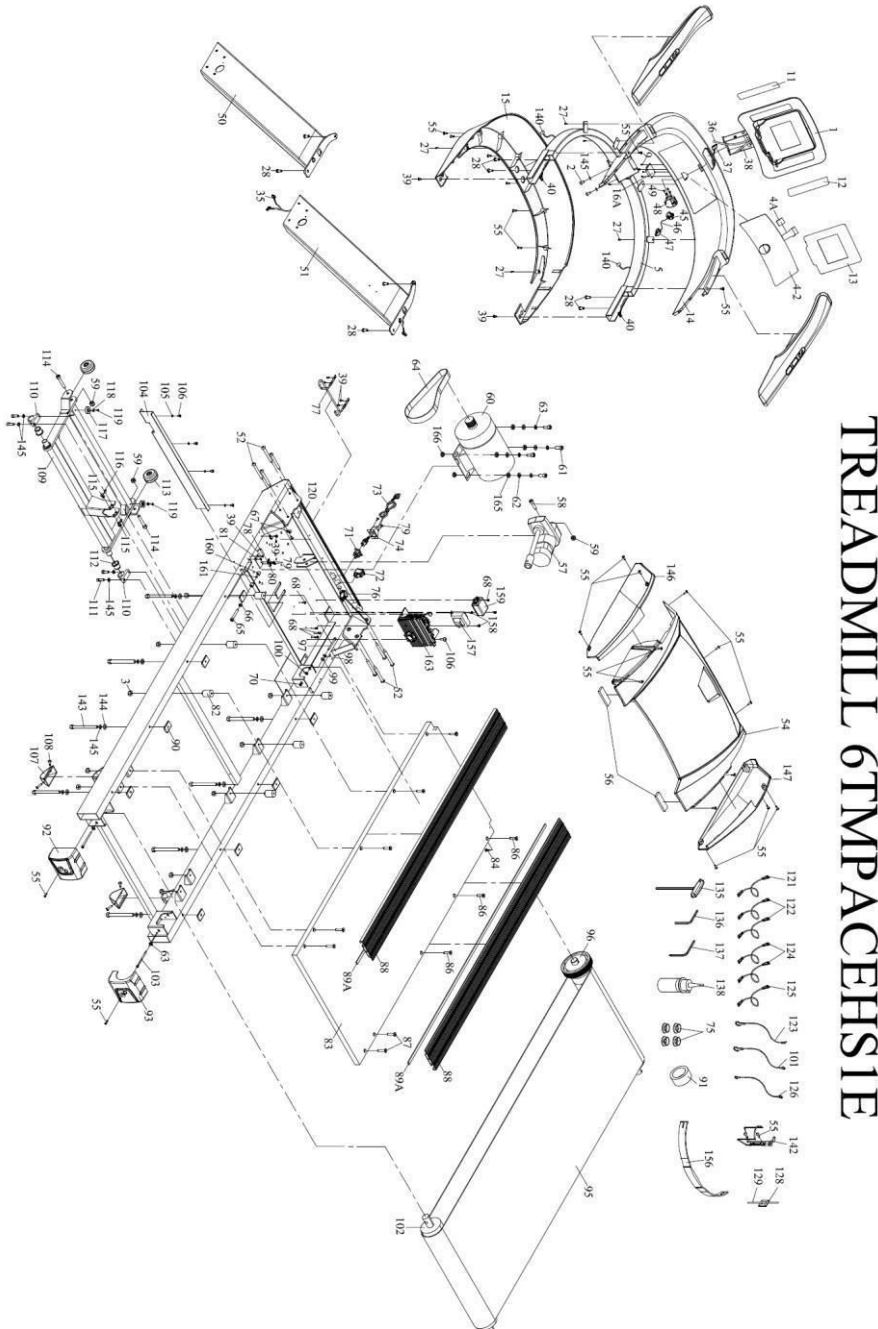
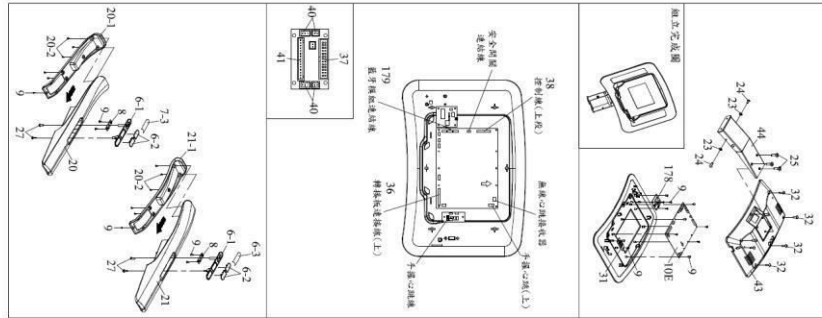

TREADMILL 6TMPACHSIE

• **P6 (Weight loss)**

SPEED CHANGES ONLY
WEIGHT LOSS

		1	2	3	4	5	6	7	8	9	10	11	12	13	14	15	16	17	18	19	20	21	22	23	24	25	26	27	28	29	30	
Level 1	(MPH)	0.5	1.0	1.5	2.0	2.0	2.0	2.5	2.5	2.5	3.0	3.0	3.0	3.0	3.5	3.5	3.5	3.5	3.0	3.0	3.0	2.5	2.5	2.5	2.0	2.0	2.0	1.5	1.5	1.0	0.5	
	(KPH)	0.8	1.6	2.4	3.2	3.2	3.2	4.0	4.0	4.0	4.8	4.8	4.8	4.8	5.6	5.6	5.6	5.6	4.8	4.8	4.8	4.0	4.0	4.0	3.2	3.2	3.2	2.4	2.4	1.6	0.8	
Level 2	(MPH)	0.5	1.0	1.5	2.5	2.5	2.5	3.0	3.0	3.0	3.5	3.5	3.5	3.5	4.0	4.0	4.0	4.0	3.5	3.5	3.5	3.0	3.0	3.0	2.5	2.5	2.5	2.0	1.5	1.0	0.5	
	(KPH)	0.8	1.6	2.4	4.0	4.0	4.0	4.8	4.8	4.8	5.6	5.6	5.6	5.6	6.4	6.4	6.4	6.4	5.6	5.6	5.6	4.8	4.8	4.8	4.0	4.0	4.0	3.2	2.4	1.6	0.8	
Level 3	(MPH)	0.5	1.0	1.5	2.5	3.0	3.0	3.5	3.5	3.5	4.0	4.0	4.0	4.0	4.5	4.5	4.5	4.5	4.0	4.0	4.0	3.5	3.5	3.5	3.0	3.0	3.0	2.5	1.5	1.0	0.5	
	(KPH)	0.8	1.6	2.4	4.0	4.8	4.8	5.6	5.6	5.6	6.4	6.4	6.4	6.4	7.2	7.2	7.2	7.2	6.4	6.4	6.4	5.6	5.6	5.6	4.8	4.8	4.8	4.0	2.4	1.6	0.8	
Level 4	(MPH)	1.0	1.5	2.0	3.0	3.5	3.5	4.0	4.0	4.0	4.5	4.5	4.5	4.5	5.0	5.0	5.0	5.0	4.5	4.5	4.5	4.0	4.0	4.0	3.5	3.5	3.5	3.0	2.0	1.5	1.0	
	(KPH)	1.6	2.4	3.2	4.8	5.6	5.6	6.4	6.4	6.4	7.2	7.2	7.2	7.2	8.0	8.0	8.0	8.0	7.2	7.2	7.2	6.4	6.4	6.4	5.6	5.6	5.6	4.8	3.2	2.4	1.6	
Level 5	(MPH)	1.0	1.5	2.0	3.0	3.5	4.0	4.5	4.5	4.5	5.0	5.0	5.0	5.0	5.5	5.5	5.5	5.5	5.0	5.0	5.0	4.5	4.5	4.5	4.0	4.0	4.0	3.5	2.0	1.5	1.0	
	(KPH)	1.6	2.4	3.2	4.8	5.6	6.4	7.2	7.2	7.2	8.0	8.0	8.0	8.0	8.8	8.8	8.8	8.8	8.0	8.0	8.0	7.2	7.2	7.2	6.4	6.4	6.4	5.6	3.2	2.4	1.6	
Level 6	(MPH)	1.0	1.5	2.0	3.5	4.0	4.5	5.0	5.0	5.0	5.5	5.5	5.5	5.5	6.0	6.0	6.0	6.0	5.5	5.5	5.5	5.0	5.0	5.0	4.5	4.5	4.5	4.0	2.0	1.5	1.0	
	(KPH)	1.6	2.4	3.2	5.6	6.4	7.2	8.0	8.0	8.0	8.8	8.8	8.8	8.8	9.6	9.6	9.6	9.6	8.8	8.8	8.8	8.0	8.0	8.0	7.2	7.2	7.2	6.4	3.2	2.4	1.6	
Level 7	(MPH)	1.5	2.0	2.5	4.0	4.5	5.0	5.5	5.5	5.5	6.0	6.0	6.0	6.0	6.5	6.5	6.5	6.5	6.0	6.0	6.0	5.5	5.5	5.5	5.0	5.0	5.0	4.5	2.5	2.0	1.5	
	(KPH)	2.4	3.2	4.0	6.4	7.2	8.0	8.8	8.8	8.8	9.6	9.6	9.6	9.6	10.4	10.4	10.4	10.4	9.6	9.6	9.6	8.8	8.8	8.8	8.0	8.0	8.0	7.2	4.0	3.2	2.4	
Level 8	(MPH)	1.5	2.0	2.5	4.0	5.0	5.5	6.0	6.0	6.0	6.5	6.5	6.5	6.5	7.0	7.0	7.0	7.0	6.5	6.5	6.5	6.0	6.0	6.0	6.0	5.5	5.5	4.5	2.5	2.0	1.5	
	(KPH)	2.4	3.2	4.0	6.4	8.0	8.8	9.6	9.6	9.6	10.4	10.4	10.4	10.4	11.2	11.2	11.2	11.2	10.4	10.4	10.4	9.6	9.6	9.6	9.6	8.8	8.8	7.2	4.0	3.2	2.4	
Level 9	(MPH)	1.5	2.0	2.5	4.0	5.5	6.0	6.5	6.5	6.5	7.0	7.0	7.0	7.0	7.5	7.5	7.5	7.5	7.0	7.0	7.0	6.5	6.5	6.5	6.0	6.0	5.5	5.0	2.5	2.0	1.5	
	(KPH)	2.4	3.2	4.0	6.4	8.8	9.6	10.4	10.4	10.4	11.2	11.2	11.2	11.2	12.0	12.0	12.0	12.0	11.2	11.2	11.2	10.4	10.4	10.4	9.6	9.6	8.8	8.0	4.0	3.2	2.4	
Level 10	(MPH)	1.5	2.0	2.5	4.0	5.5	6.5	7.0	7.0	7.0	7.5	7.5	7.5	7.5	8.0	8.0	8.0	8.0	7.5	7.5	7.5	7.0	7.0	7.0	7.0	6.5	6.5	6.0	5.5	2.5	2.0	1.5
	(KPH)	2.4	3.2	4.0	6.4	8.8	10.4	11.2	11.2	11.2	12.0	12.0	12.0	12.0	12.8	12.8	12.8	12.8	12.0	12.0	12.0	11.2	11.2	11.2	10.4	10.4	9.6	8.8	4.0	3.2	2.4	

TERMS AND CONDITIONS OF WARRANTY, WARRANTY CLAIMS

General Conditions of Warranty and Definition of Terms

All Warranty Conditions stated hereunder determine Warranty Coverage and Warranty Claim Procedure.

The seller is SAXO LTD with its registered office in Sakar Planina Street 1, Ruse, Bulgaria. Company Registration Number: 117028813, registered in the Trade Register.

According to valid legal regulations it depends whether the Buyer is the End Customer or not.

“The Buyer who is the End Customer” or simply the “End Customer” is the legal entity that does not conclude and execute the Contract in order to run or promote his own trade or business activities.

“The Buyer who is not the End Customer” is a Businessman that buys Goods or uses services for the purpose of using the Goods or services for his own business activities. The Buyer conforms to the General Purchase Agreement and business conditions to the extent specified in the Commercial Code.

These Conditions of Warranty and Warranty Claims are an integral part of every Purchase Agreement made between the Seller and the Buyer. All Warranty Conditions are valid and binding, unless otherwise specified in the Purchase Agreement, in the Amendment to this Contract or in another written agreement.

Warranty Conditions

Warranty Period

The Seller provides the Buyer a 24 months Warranty for Goods Quality, unless otherwise specified in the Certificate of Warranty, Invoice, Bill of Delivery or other documents related to the Goods. The legal warranty period provided to the Consumer is not affected.

By the Warranty for Goods Quality, the Seller guarantees that the delivered Goods shall be, for a certain period of time, suitable for regular or contracted use, and that the Goods shall maintain its regular or contracted features.

The Warranty does not cover defects resulting from:

- User's fault, i.e. product damage caused by unqualified repair work, improper assembly, not properly assembled parts
- Mechanical damages
- Regular use (e.g. wearing out of rubber and plastic parts, joints etc.)
- Unavoidable event, natural disaster
- Improper maintenance
- Adjustments made by unqualified person
- Improper maintenance, improper placement, damages caused by low or high temperature, water, inappropriate pressure, shocks, intentional changes in design or construction etc.

Claims can be accepted from the head office of SAXO OOD, located in Ruse on „TEC IZTOK“ 20 Street.

Warranty Claim Procedure

The Buyer is obliged to check the Goods delivered by the Seller immediately after taking the responsibility for the Goods and its damages, i.e. immediately after its delivery. The Buyer must check the Goods so that he discovers all the defects that can be discovered by such check.

When making a Warranty Claim the Buyer is obliged, on request of the Seller, to prove the purchase and validity of the claim by the Invoice or Bill of Delivery that includes the product's serial number, or eventually by the documents without the serial number. If the Buyer does not prove the validity of the Warranty Claim by these documents, the Seller has the right to reject the Warranty Claim.

If the Buyer gives notice of a defect that is not covered by the Warranty (e.g. in the case that the Warranty Conditions were not fulfilled or in the case of reporting the defect by mistake etc.), the Seller is eligible to require a compensation for all the costs arising from the repair. The cost shall be calculated according to the valid price list of services and transport costs.

If the Seller finds out (by testing) that the product is not damaged, the Warranty Claim is not accepted.

The Seller reserves the right to claim a compensation for costs arising from the false Warranty Claim.

In case the Buyer makes a claim about the Goods that is legally covered by the Warranty provided by the Seller, the Seller shall fix the reported defects by means of repair or by the exchange of the damaged part or product for a new one. Based on the agreement of the Buyer, the Seller has the right to exchange the defected Goods for a fully compatible Goods of the same or better technical characteristics. The Seller is entitled to choose the form of the Warranty Claim Procedures described in this paragraph.

The Seller shall settle the Warranty Claim within 30 days after the delivery of the defective Goods, unless a longer period has been agreed upon. The day when the repaired or exchanged Goods is handed over to the Buyer is considered to be the day of the Warranty Claim settlement. When the Seller is not able to settle the Warranty Claim within the agreed period due to the specific nature of the Goods defect, he and the Buyer shall make an agreement about an alternative solution. In case such agreement is not made, the Seller is obliged to provide the Buyer with a financial compensation in the form of a refund.



 **insportline**

Office:

Phone:

E-mail:

Web:

Ruse, "TEC Iztok" 20 Street

0894 566 060

office@yako.bg

www.yakosport.eu

www.insportline.bg