

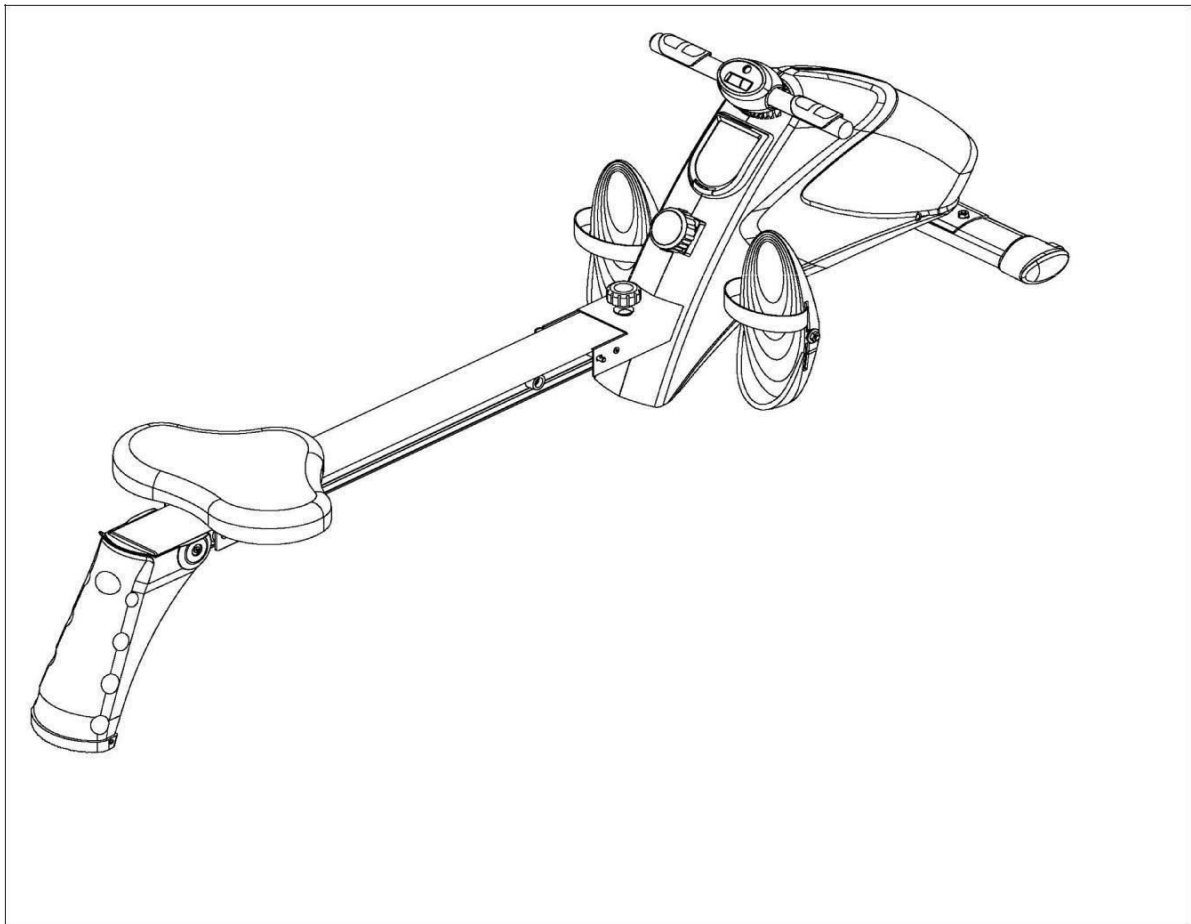

USER MANUAL – EN

IN 2812 Rowing Machine inSPORTline Amazonian



CONTENTS

- SAFETY PRECAUTIONS..... 3
- EXPLODED DIAGRAM 4
- PARTS LIST 5
- ASSEMBLY 6
- FOLDING..... 9
- RESISTANCE ADJUSTMENT 9
- EXERCISES 10
- TROUBLE SHOOTING 13
- MAINTENANCE 13
- EXERCISE COMPUTER..... 13
 - FUNCTION BUTTON..... 13
 - FUNCTIONS 13
- FUNCTION 14
- ENVIRONMENT PROTECTION 14
- TERMS AND CONDITIONS OF WARRANTY, WARRANTY CLAIMS..... 14

SAFETY PRECAUTIONS

- Keep this manual for future use.
- Ask your physician before your training. You should ask about possible problems connected with training program.
- Read all instructions. Instructions are written for safety of user and protection of the product.
- Keep away from kids.
- Kids and people with physical or mental disorder must be supervised.
- Use this product as intended by the manufacturer. Do only exercises that are intended by this product. All other exercises are considered wrong and dangerous.
- Do not modify this product.
- Keep legs and arms away from moving parts.
- Do not put any object to the ventilation.
- Do not excessive training to total exhaustion. Wrong or excessive training can lead to serious health problems or death. If you feel unusual pain or abnormal symptoms, stop immediately and ask physician for help.
- Always wear sport clothes. Do not wear loose clothes. Secure your hair. Keep towel and clothes away from moving parts.
- When someone use the product, others need to stay away in safe distance.
- Do not use if you have pet nearby.
- Owner or trainer must explain the safe use of the device.
- Assembly the product before use. Check the device before exercise. Do not use the product if it is not working as intended.
- Assembly the product on solid and flat ground. Keep distance of 0.6 m from other objects.
- Keep the device in good condition. If signs of wear appear, contact the manufacturer.
- Maintain the product as is described in the manual.
- Assembly, maintenance and setup can be done by qualify person.
- The electrical connection must meet the requirements of the country.
- Do not place anything on the construction or display of the device.
- **Maximum load capacity:** 120 kg
- **Weight:** 22 kg
- **Use:** Category HC (EN 957)

The seller is not responsible for any damage or failure caused by unauthorized service, misuse, accident, neglect, misconduct, environmental damage, corrosion caused by incorrect placement, modification without approval, sale or failure to use and maintain the machine.

RM3160-01

EXPLODED DIAGRAM

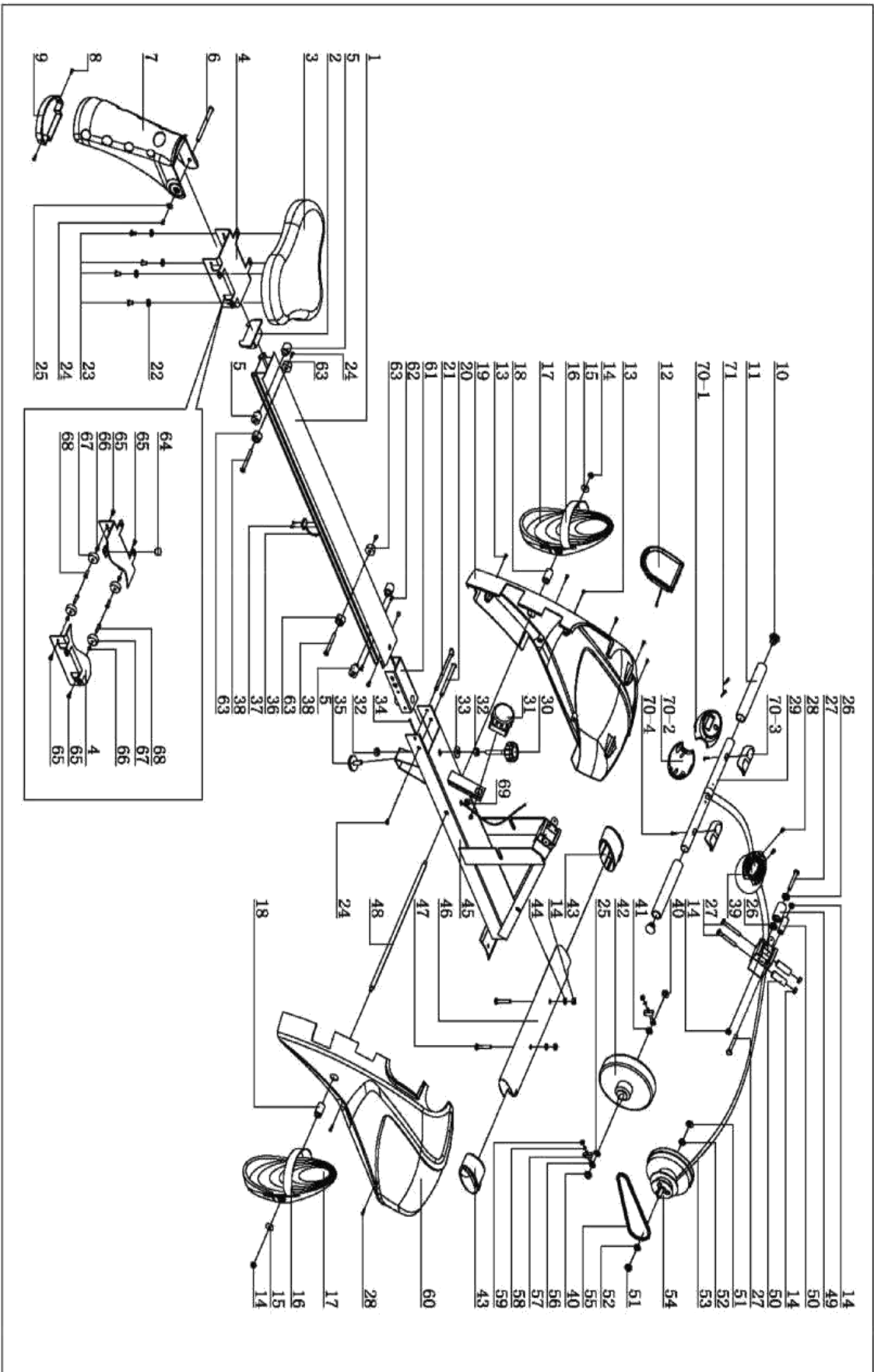

PARTS LIST

NO.	DESCRIPTION	QTY	NO.	DESCRIPTION	QTY
1.	Rower Frame	1	39.	Cushion Cover	1
2.	Cover for Rower Frame	1	40.	Nut(M10*1)	2
3.	Seat	1	41.	Nut(M10*1)	1
4.	Seat Bracket	1	42.	Fly wheel	1
5.	Pad	4	43.	Front End Cap	2
6.	Fixing Bolt (φ9.5*115)	1	44.	Curved Washer(φ8)	2
7.	Rear Stabilizer	1	45.	Main Frame	1
8.	Screw (ST4.2*10F)	7	46.	Front Stabilizer	1
9.	Rear End Cap	1	47.	Carriage Bolt (M8*50)	2
10.	End Cap	2	48.	Axle for Pedal	1
11.	Foam Grip	2	49.	Roller1(φ28*48)	1
12.	Computer	1	50.	Roller2(φ17*48)	3
13.	Screw (ST4.2*15)	4	51.	Nut(M10*1.25)	2
14.	Nut(M8)	14	52.	Nut(M10*1.25)	2
15.	Washer(φ8)	2	53.	Weave Belt	1
16.	Velcro strap	2	54.	Rub wheel	1
17.	Pedal	2	55.	Chain	1
18.	Plastic Bushing	2	56.	Nut(M6)	2
19.	Chain Cover (Left)	1	57.	U Type Bracket	2
20.	Pivot	1	58.	Spring washer	2
21.	Pull Pin	1	59.	Nut(M6)	2
22.	Washer(φ8)	4	60.	Chain Cover (Right)	1
23.	Screw(M8*15)	4	61.	U Connection Tube	1
24.	Bolt(M6*10)	4	62.	Cross Bolt (M6*10)	4
25.	Washer(φ10)	2	63.	Stopper	4
26.	Bearing	2	64.	Magnet	1
27.	Bolt(M8*65)	4	65.	Cross Bolt (M5*10)	4
28.	Cross screw(ST4.2*19)	6	66.	Tube for Roller	4

29.	Handlebar	1	67.	Wheel for Seat	4
30.	Adjustment Knob(M10*55)	1	68.	Fixing Bolt	4
31.	Tension Knob	1	69.	Clip	1
32.	Nut(M10)	2	70.	Computer for Handlebar	1
33.	Washer ($\phi 10$)	1	70-1	Upper cover for handlebar's computer	1
34.	Upper Wire	1	70-2	Low cover for handlebar's computer	1
35.	Rubber Pad	1	70-3	Hand pulse	1
36.	Lower Wire	1	70-4	Bolt	2
37.	Cross screw (ST2.9*10)	2	71.	Cross screw (ST3.5*30)	2
38.	Pivot	2			

ASSEMBLY

Step 1



Connect the rower frame (1) to the rear stabilizer (7) using the bracket provided, slot the fixing bolt $\phi 9.5 \times 115$ (6) through the bracket and lock in place using the washer (25) and M6*10 Bolt (24).

Step 2

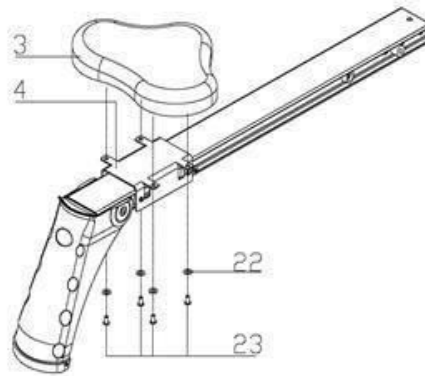

Attach the seat bracket (4) to the underside of the seat (3) using the four Washer $\phi 8$ (22) and Screw M8*15 (23).

Step 3

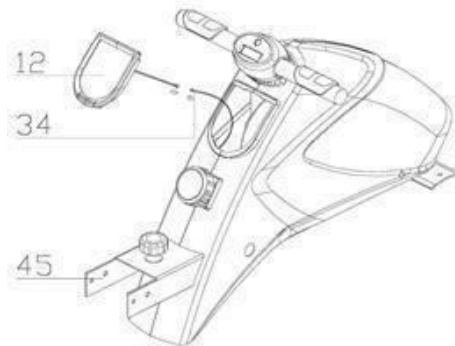

Connect upper wire (34) with Computer (12) then attach computer to the Main Frame (45).

Step 4

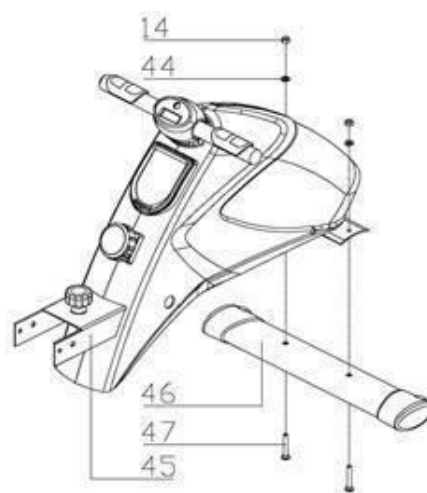

Attach the front stabilizer (46) to the underside of the Main Frame (45) using the two Carriage Bolt M8*50 (47), Curved Washer $\phi 8$ (44) and S Nut (M8) (14).

Step 5

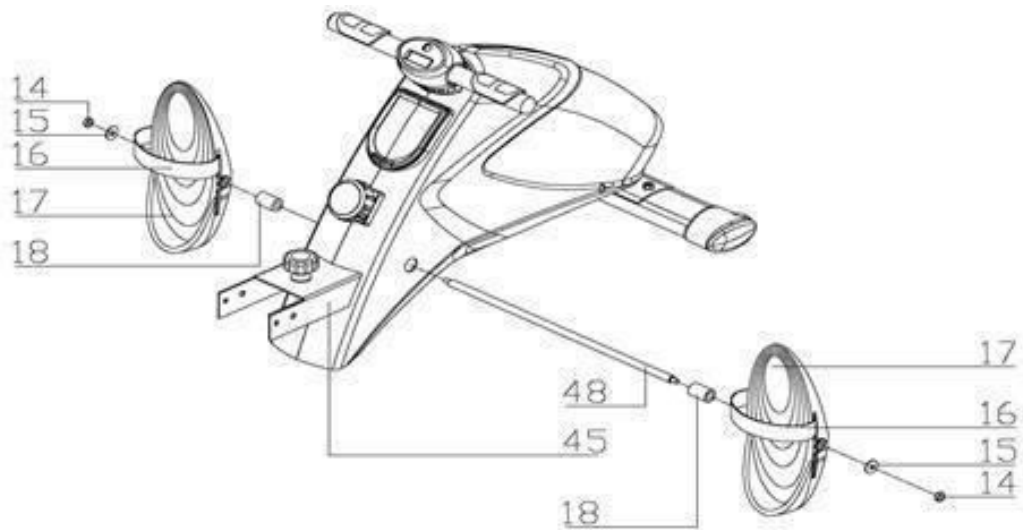

Insert the Axle for Pedal (48) to the Main Frame (45), cover the Plastic Bushing (18), pedal (17) and bigger Washer $\varnothing 8$ (15) in order. Then fix tightly by lock Nut M8 (14).

Step 6

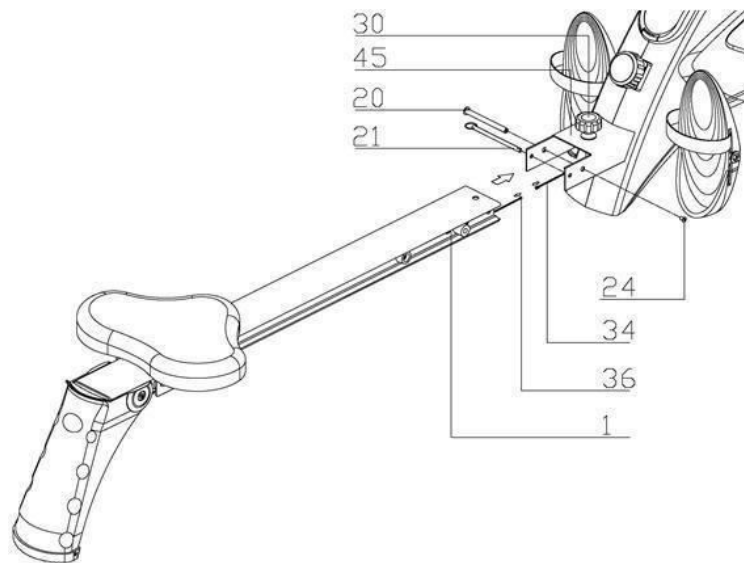

Attach rower frame (pt.48) to the main frame (45), connect upper wire (34) with lower wire (36). Fix them tightly by Pivot (20) and Bolt (24), then insert Pull Pin (21), at last tight tighten adjustment knob (30).

FOLDING

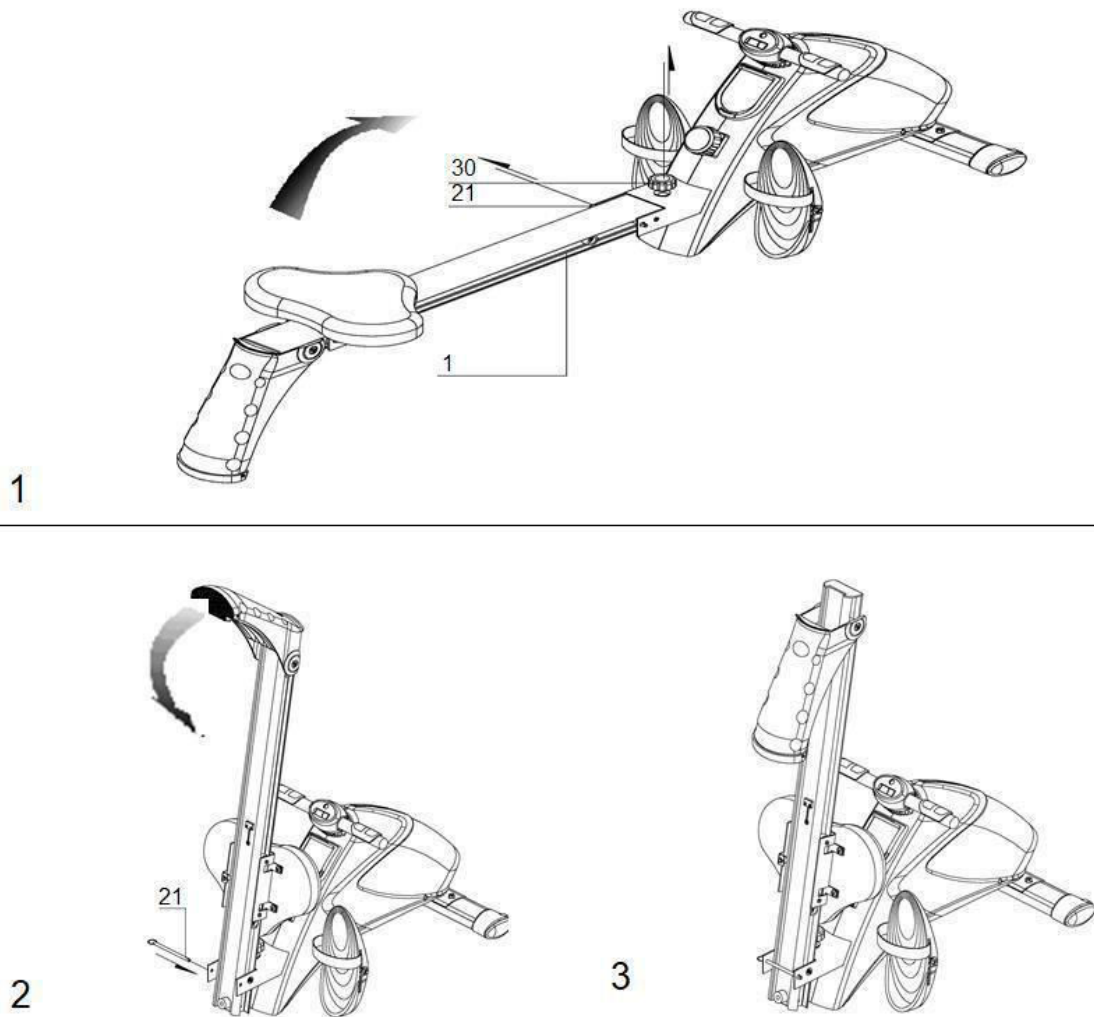

Unscrew the adjustment knob (30) from the mainframe (45) and remove the pull pin (21), then pull the rower frame (1) in towards the main housing unit and replace the pull pin to keep the rower in a folded position.

Then down the rear stabilizer (7). (NB please ensures that the sensor cables do not get trapped when tilting the mainframe bar in towards the main housing).

RESISTANCE ADJUSTMENT

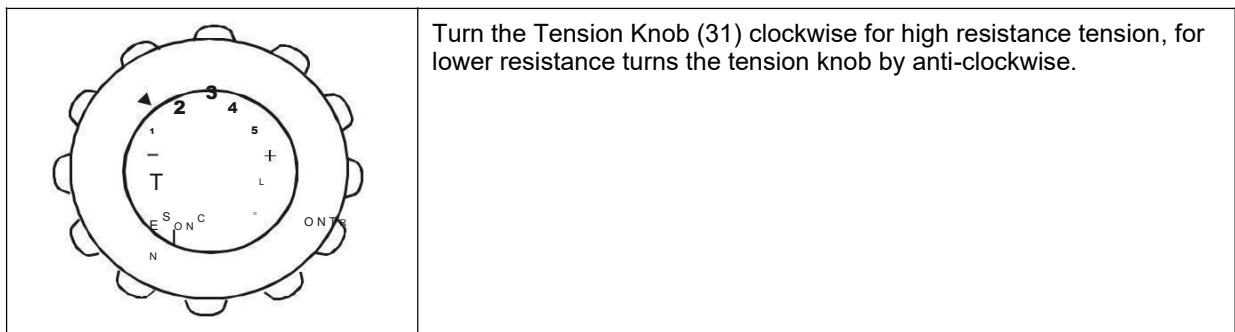





EXERCISES

Using your **MAGNETIC ROWING MACHINE** will provide you with several benefits. It will improve your physical fitness, tone your muscles and, in conjunction with a calorie-controlled diet, help you lose weight.

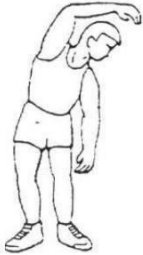
The Warm-Up Phase

This stage helps get the blood flowing around the body and the muscles working properly. It will also reduce the risk of cramp and muscle injury. It is advisable to do a few stretching exercises as shown below. Each stretch should be held for approximately 30 seconds. Do not force or jerk your muscles into a stretch - if it hurts, **STOP**.

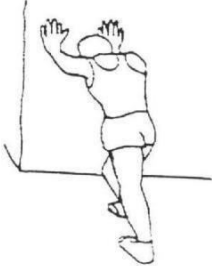
	Sides and hips
	Back thighs
	Front thighs
	Inner thighs
	Calves and Achilles tendon

Rowing is an extremely effective form of exercise. It strengthens the heart and improves circulation as well as exercising all the major muscle groups; the back, waist, arms, shoulders, hips and legs.

The Exercise Phase

This is the stage where you put the effort in. After regular use, the muscles in your legs will become more flexible. Work at your own pace but be sure to maintain a steady tempo throughout. The rate of work should be enough to raise your heartbeat into the target zone shown on the graph below.

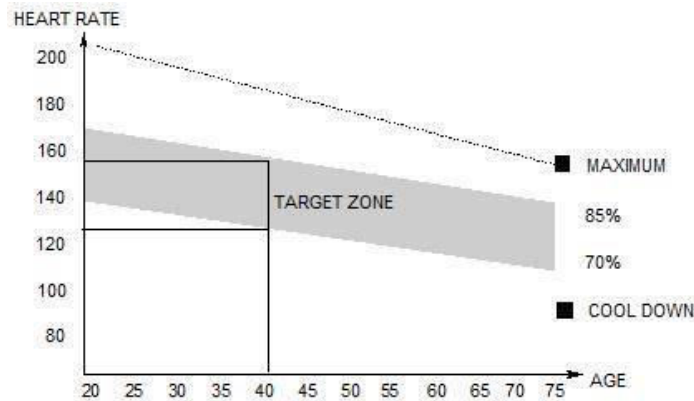

Cooling-Down Phase

This stage is to let your cardio-vascular system and muscles wind down. This is a repeat of the warm-up phase. First, reduce your tempo and continue at this slower pace for approximately 5 minutes before you get off your Exercise Bike. The stretching exercises should now be repeated, again remembering not to force or jerk your muscles into the stretch.

As you get fitter you may need to train longer and harder. It is advisable to train at least three times a week, and if possible, to space your workouts evenly throughout the week.

Basic exercise

- 1) Sit on the saddle and fasten your feet to the pedals using the Velcro straps. Then take hold of the rowing bar.
- 2) Take up the starting position, leaning forward with your arms straight and knees bent as shown in (Pic 1).
- 3) Push yourself backwards, straightening your back and legs at the same time (Pic 2).
- 4) Continue this movement until you are leaning slightly backwards, during this stage you should bring your arms out of the side. (Pic 3). Then return to stage 2 and repeat. See attached.

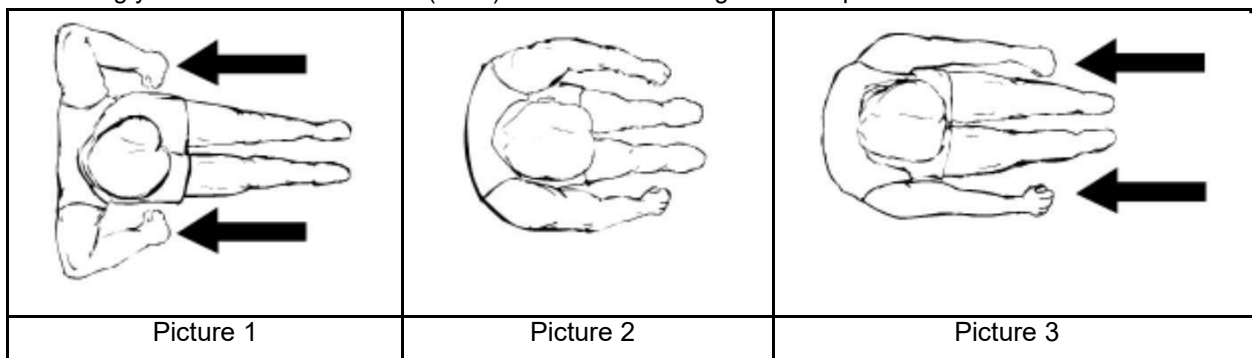

Training Time

Rowing is a strenuous form of exercise, because of this it is best to start with a short, easy exercise programmed and build up to longer and harder workouts. Start rowing for about 5 minutes and as you progress, increase the length of your work out to match your improving level of fitness. You should eventually be capable of rowing for 15-20 minutes, but do not try to achieve this too quickly.

Try to train on alternate days, 3 times a week. This gives your body time to recover between workouts.

Alternate Rowing Styles.

Arms Only Rowing

This exercise will tone muscles in your arms, shoulders, back and stomach. Sit as shown in Pic 4 with your legs straight, lean forward and grasp the handles. In a gradual and controlled manner lean back to just past the upright position continuing to pull the handles towards your chest. Return to the starting position and repeat. See attached.

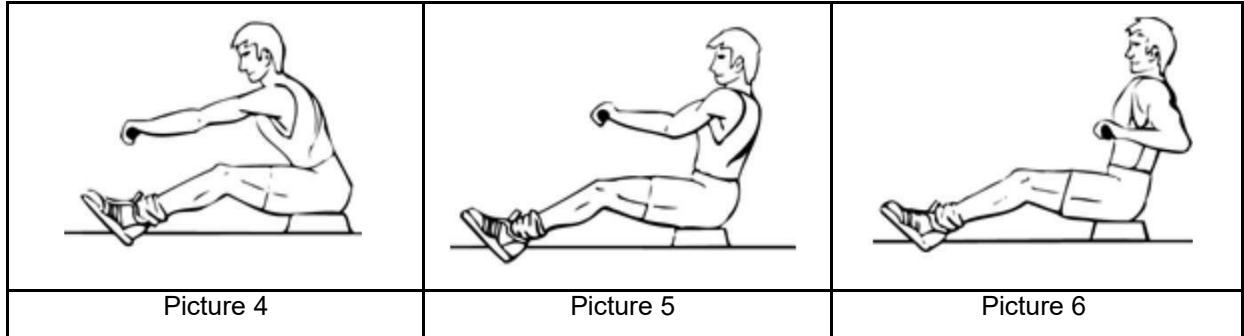

Legs Only Rowing

This exercise will help tone muscles in your legs and back. With your back straight and arms out stretched, bend your legs until you are grasping the rowing arm handles in the starting position, Pic 7. Use your legs to push your body back whilst keeping your arms and back straight

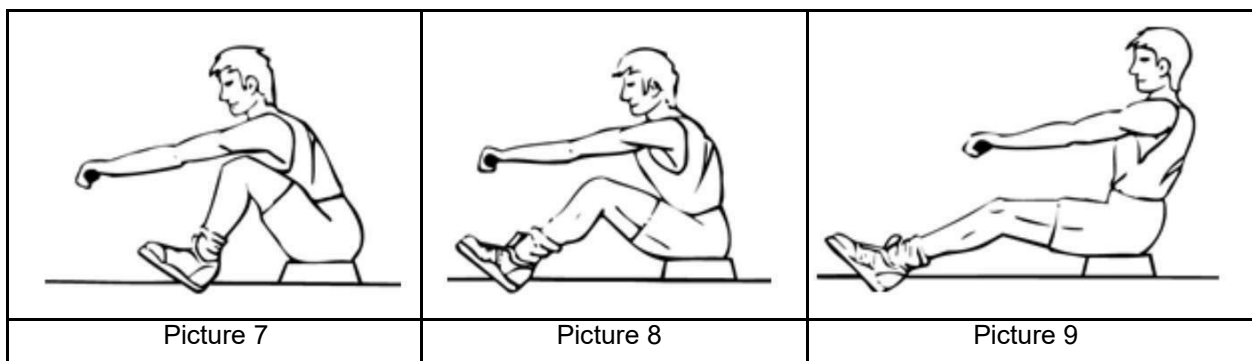

MUSCLE TONING

To tone muscle while on your **MAGNETIC ROWING MACHINE** you will need to have the resistance set quite high. This will put more strain on our leg muscles and may mean you cannot train for as long as you would like. If you are also trying to improve your fitness you need to alter your training program. You should train as normal during the warm up and cool down phases, but towards the end of the exercise phase you should increase resistance making your legs work harder. You will have to reduce your speed to keep your heart rate in the target zone.

WEIGHT LOSS

The important factor here is the amount of effort you put in. The harder and longer you work the more calories you will burn. This is effectively the same as if you were training to improve your fitness, the difference being the goal.

TROUBLE SHOOTING

Computer not working correctly. If your computer is not working correctly, please check whether the lower wire is connected to the upper wire, and make sure that the upper wire is connected to the computer. If you have checked for the above, and the computer still not working, then please make sure the batteries are still working and are installed correctly in the computer.

MAINTENANCE

Before using the **MAGNETIC ROWING MACHINE**, always make sure all bolts/nuts are fully tightened.

EXERCISE COMPUTER

FUNCTION BUTTON

MODE PRESS TO SELECT FUNCTION OF COUNT, TIME, AND CALORIES FOR PRESETTING.

RESET PRESS TO RESET EACH SINGLE FUNCTION OF COUNT, TIME, AND CALORIES.

SET PRESS TO SET COUNT, TIME, AND CALORIES.



FUNCTIONS

SCAN – Automatically scans each function in sequence.

COUNT UP – The monitor will display current stroke numbers from 0 to 9999.

COUNT DOWN - The monitor will start to count from pre-set stroke numbers down to 0 soon as training starts.

TIME COUNT UP – The monitor will accumulate training time from 0:00 to 99:59.

COUNT DOWN - The monitor will start to count from pre-set time down to 0:00 as soon as training starts.

TOTAL COUNT UP - the total working counts which will be kept displaying on the LCD to show the user's total counts.

COUNT DOWN –The monitor will start to count from pre-set total countdown to 0:00 as soon as training starts.

CALORIES COUNT UP – The monitor will accumulate calories consumption from 0 to 999 cal.

COUNT DOWN – The monitor will start to count from pre-set calories down to 0 as soon as training starts.

(this data is a rough guide for comparison of different exercise sessions which cannot be used in medical treatment).

Note:

Without signal transferred to the computer for 5 minutes, the LCD will shut off automatically to conserve the battery power.

Press "mode" button or start exercise on the equipment shall turn the power on.

Press and hold "mode" button for 4 seconds, all value will be reset to zero.

The computer operates with 1 pc 1.5 v AAA size batteries.

FUNCTION BUTTON

Press to have handgrip heart rate figures display on the monitor.

FUNCTION

PULSE The monitor will display the user's heart rate while exercising. you will see your current heart rate (bpm) display on the LCD during exercising. when you start to exercise, you must hold on grips with both hands, after 30 seconds to max. 1 minute, the pulse figure will display on the LCD. if you hold on the grip with one hand only, the pulse figure display will become unstable. for the pulse readout accuracy reason, we'll suggest you hold on both hands during exercising. you may also pre-set target pulse to assist training. as soon as your current heart rate is exceeding the target figure, the monitor starts to alarm to remind the user.

Note:

When there is no signal been transferred into the monitor for 4 minutes, the monitor display will shut off automatically.

If improper display on monitor, please re-install batteries to have a good result.

The monitor requires 2 pcs of 1.5v AAA size or um-3 batteries.

Batteries should be removed from the device if not used for prolonged periods. always change both batteries at the same time.

ENVIRONMENT PROTECTION

After the product lifespan expired or if the possible repairing is uneconomic, dispose it according to the local laws and environmentally friendly in the nearest scrapyard.

By proper disposal you will protect the environment and natural sources. Moreover, you can help protect human health. If you are not sure in correct disposing, ask local authorities to avoid law violation or sanctions.

Don't put the batteries among house waste but hand them in to the recycling place.

TERMS AND CONDITIONS OF WARRANTY, WARRANTY CLAIMS

General Conditions of Warranty and Definition of Terms

All Warranty Conditions stated hereunder determine Warranty Coverage and Warranty Claim Procedure.

The seller is SAXO LTD with its registered office in Sakar Planina Street 1, Ruse, Bulgaria.
Company Registration Number: 117028813, registered in the Trade Register.

According to valid legal regulations it depends whether the Buyer is the End Customer or not.

“The Buyer who is the End Customer” or simply the “End Customer” is the legal entity that does not conclude and execute the Contract in order to run or promote his own trade or business activities.

“The Buyer who is not the End Customer” is a Businessman that buys Goods or uses services for the purpose of using the Goods or services for his own business activities. The Buyer conforms to the General Purchase Agreement and business conditions to the extent specified in the Commercial Code.

These Conditions of Warranty and Warranty Claims are an integral part of every Purchase Agreement made between the Seller and the Buyer. All Warranty Conditions are valid and binding, unless otherwise specified in the Purchase Agreement, in the Amendment to this Contract or in another written agreement.

Warranty Conditions

Warranty Period

The Seller provides the Buyer a 24 months Warranty for Goods Quality, unless otherwise specified in the Certificate of Warranty, Invoice, Bill of Delivery or other documents related to the Goods. The legal warranty period provided to the Consumer is not affected.

By the Warranty for Goods Quality, the Seller guarantees that the delivered Goods shall be, for a certain period of time, suitable for regular or contracted use, and that the Goods shall maintain its regular or contracted features.

The Warranty does not cover defects resulting from:

- User's fault, i.e. product damage caused by unqualified repair work, improper assembly, not properly assembled parts
- Mechanical damages
- Regular use (e.g. wearing out of rubber and plastic parts, joints etc.)
- Unavoidable event, natural disaster
- Improper maintenance
- Adjustments made by unqualified person
- Improper maintenance, improper placement, damages caused by low or high temperature, water, inappropriate pressure, shocks, intentional changes in design or construction etc.

Claims can be accepted from the head office of SAXO OOD, located in Ruse on „TEC IZTOK“ 20 Street.

Warranty Claim Procedure

The Buyer is obliged to check the Goods delivered by the Seller immediately after taking the responsibility for the Goods and its damages, i.e. immediately after its delivery. The Buyer must check the Goods so that he discovers all the defects that can be discovered by such check.

When making a Warranty Claim the Buyer is obliged, on request of the Seller, to prove the purchase and validity of the claim by the Invoice or Bill of Delivery that includes the product's serial number, or eventually by the documents without the serial number. If the Buyer does not prove the validity of the Warranty Claim by these documents, the Seller has the right to reject the Warranty Claim.

If the Buyer gives notice of a defect that is not covered by the Warranty (e.g. in the case that the Warranty Conditions were not fulfilled or in the case of reporting the defect by mistake etc.), the Seller is eligible to require a compensation for all the costs arising from the repair. The cost shall be calculated according to the valid price list of services and transport costs.

If the Seller finds out (by testing) that the product is not damaged, the Warranty Claim is not accepted.

The Seller reserves the right to claim a compensation for costs arising from the false Warranty Claim.

In case the Buyer makes a claim about the Goods that is legally covered by the Warranty provided by the Seller, the Seller shall fix the reported defects by means of repair or by the exchange of the damaged part or product for a new one. Based on the agreement of the Buyer, the Seller has the right to exchange the defected Goods for a fully compatible Goods of the same or better technical characteristics. The Seller is entitled to choose the form of the Warranty Claim Procedures described in this paragraph.

The Seller shall settle the Warranty Claim within 30 days after the delivery of the defective Goods, unless a longer period has been agreed upon. The day when the repaired or exchanged Goods is handed over to the Buyer is considered to be the day of the Warranty Claim settlement. When the Seller is not able to settle the Warranty Claim within the agreed period due to the specific nature of the Goods defect, he and the Buyer shall make an agreement about an alternative solution. In case such agreement is not made, the Seller is obliged to provide the Buyer with a financial compensation in the form of a refund.



 **insportline**

Office:

Phone:

E-mail:

Web:

Ruse, "TEC Iztok" 20 Street

0894 566 060

office@yako.bg

www.yakosport.eu

www.insportline.bg