



USER MANUAL – EN

IN 10505 Abdominal Trainer inSPORTline AB Lifter Easy



IMPORTANT!

Please read all instructions carefully before using this product. Retain this manual for future reference.

CONTENTS

IMPORTANT SAFETY NOTICE..... 3
ASSEMBLY 4
RESISTANCE 6
STORAGE 6
EXPLODED DIAGRAM..... 7
PARTS LIST 8
MONITOR INSTRUCTIONS 9
TERMS AND CONDITIONS OF WARRANTY, WARRANTY CLAIMS..... 9

Dear Customer,

the manufacturer is constantly improving all types and models. Please understand that changes to the delivered product in terms of form, features and technology are thus possible at any time.

Therefore no claims may be derived from the information, illustrations and descriptions in this manual. Reprint, duplication or translation, also of excerpts, is not permitted without the written permission of the manufacturer.

All rights according to the law or to copyright law are expressly reserved by the manufacturer.

Subject to alterations.

IMPORTANT SAFETY NOTICE

Note the following precautions before assembling or operating the machine.

1. THE MAXIMUM WEIGHT CAPACITY OF THE MACHINE IS 100 KGS. Persons whose body weight exceeds this limit should NOT use this machine.
2. Keep children and pets away from the machine all times. DO NOT leave unattended children in the same room with the machine.
3. If the user experiences dizziness, nausea, chest pain, or any other abnormal symptoms. STOP the workout at once. CONSULT A PHYSICIAN IMMEDIATELY.
4. Position the machine on a clear, level surface. Place mat under the unit to help keep the machine stable and to protect flooring.
5. Always wear appropriate workout clothing when exercising. Running or aerobic shoes are also required.
6. Use the machine only for its intended use as described in this manual.
7. DO NOT use any other accessories not recommended by the manufacturer.
8. DO NOT place any sharp objects around the machine.
9. Handicapped or disabled persons should not use the machine without the presence of a qualified health professional or physician.
10. Before exercising, always do stretching first.
11. NEVER operate the machine if it is not functioning properly

WARNING: BEFORE BEGINNING THIS OR ANY EXERCISE PROGRAM, CONSULT YOUR PHYSICIAN FIRST. THIS IS ESPECIALLY IMPORTANT FOR INDIVIDUALS OVER THE AGE OF 35 OR PERSONS WITH PRE-EXISTING HEALTH PROBLEMS. READ ALL INSTRUCTIONS BEFORE USING. THANE FITNESS ASSUMES NO RESPONSIBILITY FOR PERSONAL INJURY OR PROPERTY DAMAGE SUSTAINED BY OR THROUGH THE USE OF THIS PRODUCT.

SAVE THESE INSTRUCTIONS





ASSEMBLY

BEFORE YOU BEGIN

1. Locate a comfortable work site. Assemble your machine in an open space with adequate ventilation and lighting. Because the machine is portable, to some extent, you need not assemble it exactly where it is to be used. For your convenience, however, you should avoid hauling the machine across excessive distances, through narrow passage ways or over staircases once its assembly is complete.
2. Find your tools. You will need the following tools to assemble the machine.
 - Standard screwdriver
 - Allen key
3. Review all safety guidelines in this manual.

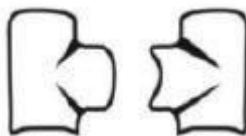
Identify your hardware

4. Organize your bolts and nuts before assembly. Nuts are identified by the diameter of their cavities. For more information, refer to exploded view diagram and parts list of this manual.

 <p>(30) Plastic front cover – 1pc</p>	 <p>(31) Plastic handle cover – 2pcs</p>	 <p>(5) Screw $\varnothing 4 \times 16 \text{mm}$ – 1pc</p>
 <p>(17) Bolt $\varnothing 8 \times 12 \text{mm}$ – 4pcs</p>	 <p>(29) Pin – 1pc</p>	

ASSEMBLY STEPS

STEP 1: INSTALL THE HANDLEBAR

Attach Handlebar (3) onto the Sliding tube frame (1) with Bolts (17) and Arc washers (22).

Attach the Foam grips (6) to the cross-bar of Sliding tube frame (1).

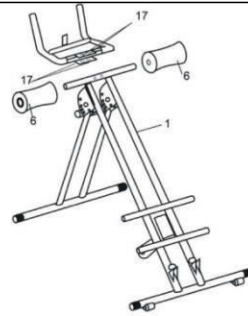

STEP 2: ATTACH FOAM GRIPS

Attach the Foam grips (7) onto the Knee frame (4).

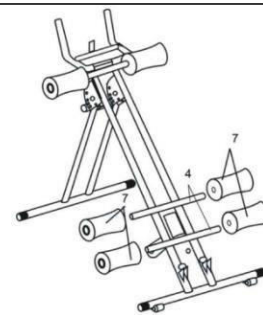

STEP 3: ATTACH THE MONITOR

Attach the monitor (12) to the Handlebar (3). Then attach the connector A to connector B as shown in the picture.

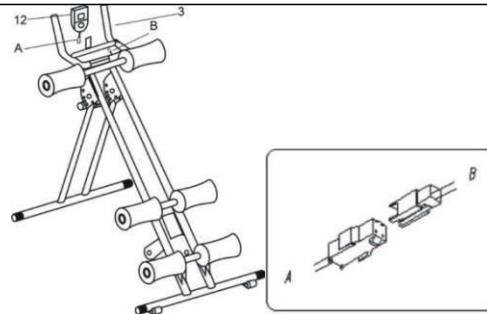

STEP 4: ATTACH THE COVER

Put the plastic handle cover (31) on the handle bar (3).

Put the Plastic front cover (30) and use the screw (5) to lock it tight.

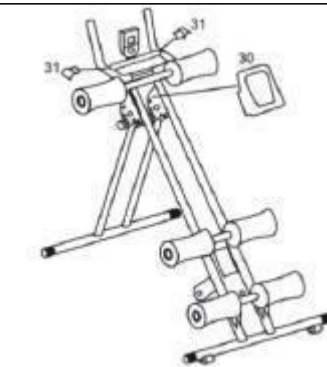

RESISTANCE

Based on the traditional Sun Salutation in the yoga the plank pose has time tested benefits including power, flexibility and balance all working together in perfect harmony. The machine is the only workout that gives you the perfect plank positioning. Use any of the 4 resistance levels. Start from D-EASY if you are a beginner or if you just want to do more reps. Then you can move up to 2 different intermediate level settings (B-HARD, C-MEDIUM). And finally the extreme level lets you get the highest level of resistance on the machine.

Remove the Pin (29) from Sliding tube frame (1). You can choose the levels (A-EXTREME, B-HARD, C-MEDIUM, D-EASY) for exercise as shown below.

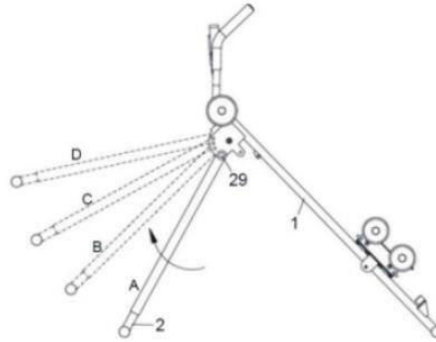

STORAGE

After exercise, remove the Pin (29) from Sliding tube frame (1). Fold the machine and fix the frames by the Pin (29) as shown below. Please keep it in a clean and dry place.

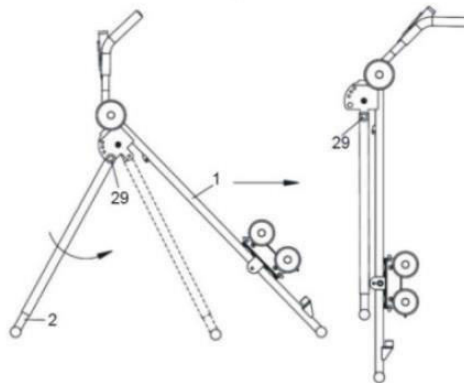

EXPLODED DIAGRAM

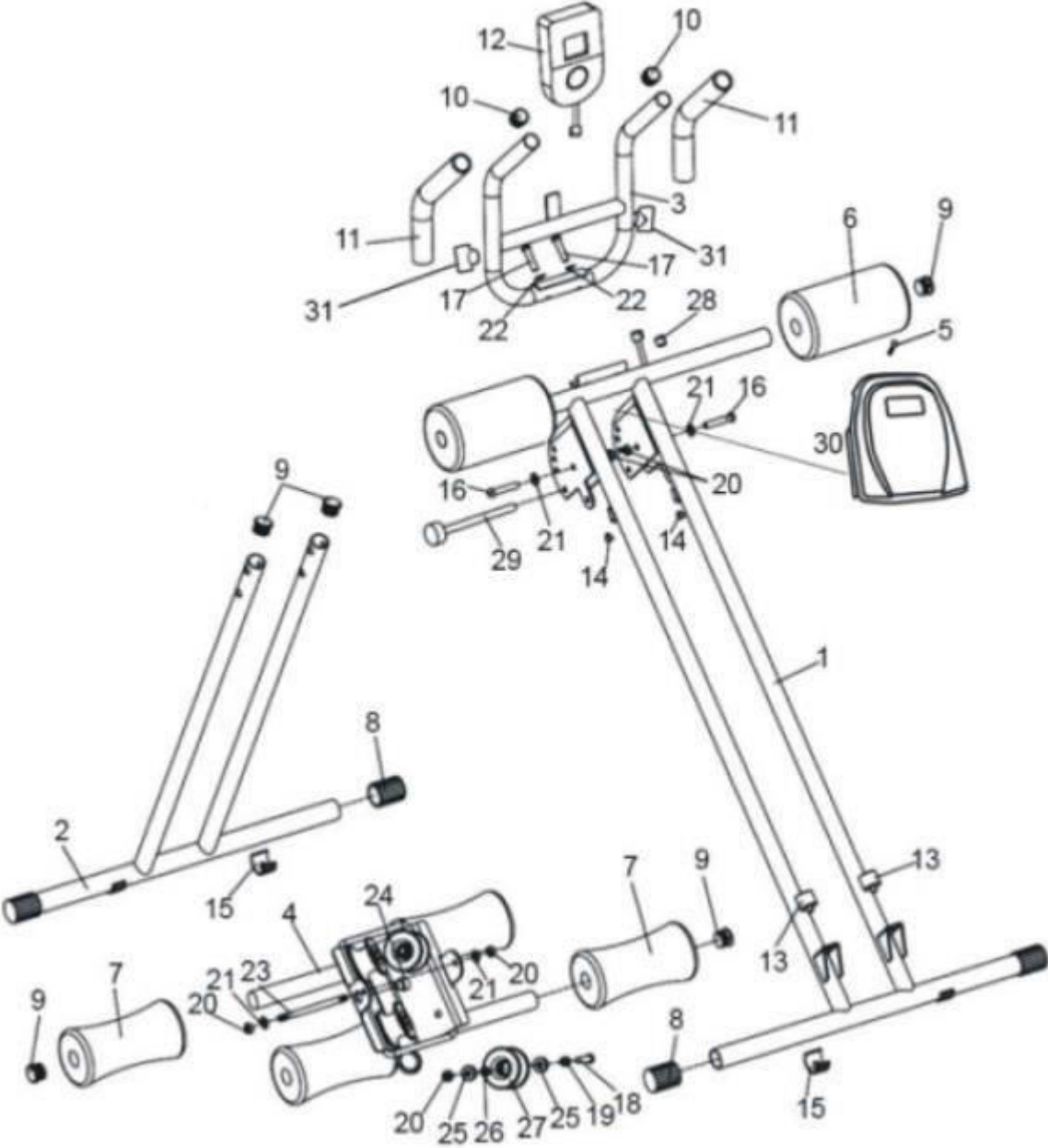

PARTS LIST

NO.	DESCRIPTION	QTY	REMARK
1	Sliding tube frame	1	
2	Front post	1	
3	Handlebar	1	
4	Knee frame	1	
5	Screw	1	ø4x15
6	Foam grip	2	ø23x80xL160
7	Foam grip	4	ø23x67xL160
8	End cap	4	
9	End cap	8	
10	End cap	2	
11	Handlebar grip	2	ø20x30xL205
12	Monitor	1	
13	Cushion	2	
14	Cushion	2	
15	Foot pad	4	
16	Bolt	2	M8xL45
17	Bolt	4	M8xL10
18	Bolt	4	D10x1.5
19	Big spacer	4	ø12xø8.2x9
20	Nylon nut	8	M8
21	Flat washer	8	M8
22	Arc washer	2	M8
23	Axle	1	M8xL180
24	Magnet	1	ø17x8
25	Bearing	8	608Z
26	Spacer	4	ø13xø8.5x5
27	Roller wheel	4	ø55x30
28	Stopple	1	ø12
29	Pin	1	
30	Plastic front cover	1	
31	Plastic handle cover	2	

MONITOR INSTRUCTIONS



SPECIFICATIONS

TIME	00:00-99:59 MIN:SEC
COUNT	0-9999 TIMES
CALORIES (CAL)	0-9999 KCAL
STRIDES/MIN (REPS/MIN)	0.9999 TIMES/MIN

OPERATING KEYS

MODE: This key lets you select and lock on to a particular function you want.

OPERATION PROCEDURES

AUTO ON/OFF:

- The system turns on when any key is pressed or when it receives a signal input from the speed sensor.
- The system turns off automatically when the sensor has no signal input or no key are pressed for 4 or 5 minutes.

RESET:

- The unit can be reset by either changing batteries or pressing the MODE key for 3 or 4 seconds

FUNCTIONS:

1. TIME: Press the MODE button until the pointer reaches TIME. Automatically collects exercise time when start exercising.
2. COUNT: Displays current counts during the time of your exercise.
3. CALORIES (CAL): Press the MODE button until the pointer reaches CALORIE (CAL). Automatically collects exercise calories when start exercising.
4. STRIDES/MIN: Press the MODE button until the pointer reaches STRIDES/MIN. Automatically collects the counts per minute when start exercising.
5. SCAN: Automatically displays the following functions in the following order: TIME - CALORIE - STRIDES/MIN.

BATTERIES:

If the monitor screen cannot work properly, please replace the battery to have good results. This monitor uses 1 battery "AA" or UM-3. You can replace the battery in the same size.

TERMS AND CONDITIONS OF WARRANTY, WARRANTY CLAIMS

General Conditions of Warranty and Definition of Terms

All Warranty Conditions stated hereunder determine Warranty Coverage and Warranty Claim Procedure. Conditions of Warranty and Warranty Claims are governed by Act No. 40/1964 Coll. Civil Code, Act No. 513/1991 Coll., Commercial Code, and Act No. 634/1992 Coll., Consumer Protection Act, as amended, also in cases that are not specified by these Warranty rules.

The seller is SEVEN SPORT s.r.o. with its registered office in Borivojova Street 35/878, Prague 13000, Company Registration Number: 26847264, registered in the Trade Register at Regional Court in Prague, Section C, Insert No. 116888.

According to valid legal regulations it depends whether the Buyer is the End Customer or not.

“The Buyer who is the End Customer” or simply the “End Customer” is the legal entity that does not conclude and execute the Contract in order to run or promote his own trade or business activities.

“The Buyer who is not the End Customer” is a Businessman that buys Goods or uses services for the purpose of using the Goods or services for his own business activities. The Buyer conforms to the General Purchase Agreement and business conditions to the extent specified in the Commercial Code.

These Conditions of Warranty and Warranty Claims are an integral part of every Purchase Agreement made between the Seller and the Buyer. All Warranty Conditions are valid and binding, unless otherwise specified in the Purchase Agreement, in the Amendment to this Contract or in another written agreement.

Warranty Conditions

Warranty Period

The Seller provides the Buyer a 24 months Warranty for Goods Quality, unless otherwise specified in the Certificate of Warranty, Invoice, Bill of Delivery or other documents related to the Goods. The legal warranty period provided to the Consumer is not affected.

By the Warranty for Goods Quality, the Seller guarantees that the delivered Goods shall be, for a certain period of time, suitable for regular or contracted use, and that the Goods shall maintain its regular or contracted features.

The Warranty does not cover defects resulting from:

User's fault, i.e. product damage caused by unqualified repair work, improper assembly, insufficient insertion of seat post into frame, insufficient tightening of pedals and cranks

Improper maintenance

Mechanical damages

Regular use (e.g. wearing out of rubber and plastic parts, joints etc.)

Unavoidable event, natural disaster

Adjustments made by unqualified person

Improper maintenance, improper placement, damages caused by low or high temperature, water, inappropriate pressure, shocks, intentional changes in design or construction etc.

Warranty Claim Procedure

The Buyer is obliged to check the Goods delivered by the Seller immediately after taking the responsibility for the Goods and its damages, i.e. immediately after its delivery. The Buyer must check the Goods so that he discovers all the defects that can be discovered by such check.

When making a Warranty Claim the Buyer is obliged, on request of the Seller, to prove the purchase and validity of the claim by the Invoice or Bill of Delivery that includes the product's serial number, or eventually by the documents without the serial number. If the Buyer does not prove the validity of the Warranty Claim by these documents, the Seller has the right to reject the Warranty Claim.

If the Buyer gives notice of a defect that is not covered by the Warranty (e.g. in the case that the Warranty Conditions were not fulfilled or in the case of reporting the defect by mistake etc.), the Seller is eligible to require a compensation for all the costs arising from the repair. The cost shall be calculated according to the valid price list of services and transport costs.

If the Seller finds out (by testing) that the product is not damaged, the Warranty Claim is not accepted. The Seller reserves the right to claim a compensation for costs arising from the false Warranty Claim.

In case the Buyer makes a claim about the Goods that is legally covered by the Warranty provided by the Seller, the Seller shall fix the reported defects by means of repair or by the exchange of the damaged part or product for a new one. Based on the agreement of the Buyer, the Seller has the right to exchange the defected Goods for a fully compatible Goods of the same or better technical characteristics. The Seller is entitled to choose the form of the Warranty Claim Procedures described in this paragraph.

The Seller shall settle the Warranty Claim within 30 days after the delivery of the defective Goods, unless a longer period has been agreed upon. The day when the repaired or exchanged Goods is handed over to the Buyer is considered to be the day of the Warranty Claim settlement. When the Seller is not able to settle the Warranty Claim within the agreed period due to the specific nature of the Goods defect, he and the Buyer shall make an agreement about an alternative solution. In case such agreement is not made, the Seller is obliged to provide the Buyer with a financial compensation in the form of a refund.



Oficiu:

Telefon:

E-mail:

Web:

Русе, ул. "ТЕЦ Изток" 20

070080020 / 09897612190

office@yako.bg

www.insportline.bg